

# Portable compact disc player

# Service Service Service



AX3200 AX3201 AX3202  
AX3203 AX3204 AX3205  
AX3210 AX3211 AX3212  
AX3213 AX3214 AX3215

PRODUCT FAMILY TARGET ESP

# Service Manual



## TABLE OF CONTENTS

Technical specification .....	1-1
Features and Accessories .....	1-2
Connections and controls .....	1-3
Instruction For Use .....	1-4..1-6
Safety & Warnings .....	1-7
<b>Service hints</b>	
Repair positions .....	2-1
Dismantling CD-door .....	2-1
Handling chip components .....	2-2
Service tools .....	2-2
Pin description of ICs .....	3-1..3-5
Start-up procedure .....	3-6
Service Test Program .....	3-7..3-8
Blockdiagram .....	3-9

## Circuit diagrams

Supply part .....	4-1
Audio part .....	4-2
DSP part .....	4-3

## Printed circuit board

Componentside view .....	4-4
Copperside view .....	4-5
Exploded view .....	5-1
Mechanical partslist .....	5-1
Electrical partslist .....	6-1..6-3

**CLASS 1  
LASER PRODUCT**

© Copyright 2001 Philips Consumer Electronics B.V. Eindhoven, The Netherlands  
All rights reserved. No part of this publication may be reproduced, stored in a retrieval  
system or transmitted, in any form or by any means, electronic, mechanical, photocopying,  
or otherwise without the prior permission of Philips.

Published by LX 0251 Service Audio Printed in The Netherlands Subject to modification

GB 3140 78 5 32250



# PHILIPS

## TECHNICAL SPECIFICATION

### General

Dimensions (WxHxD)	: 128x30x139.5mm
Weight without batteries	: 220g

### Laser

Output power	: <5mW (3mW typ.)
Wavelength	: 780nm

### Shock resistance

+X/-X direction	: $\geq 2.5g$
+Y/-Y direction	: $\geq 2.5g$
+Z/-Z direction	: $\geq 2.0g$

### Power supply modes

SUPPLY MODE	Voltage range
DC-in socket	2.9 - 6.0V
Primary batteries 2 x LR6	1.7 - 3.6V
Rechargeable batteries AY3362 (1200mAh)	1.7 - 3.6V

### Battery lifetime

BATTERY TYPE	CD MODE PSM IN	CD MODE ESP=ON
Primary batteries 2 x LR6	$\geq 19h$ (24h typ.)	$\geq 16h$ (21h typ.)
Rechargeable batteries AY3362 (1200mAh)	$\geq 10h$ (12h typ.)	$\geq 8h$ (10h typ.)

### Battery level detection – CD mode

DETECTION LEVEL	Primary batteries	Rechargeable batteries
Battery empty	1.8V +100/-50mV	1.8V +100/-50mV
Battery weak 1	battery empty level + 0.75V $\pm 100mV$	battery empty level + 0.7V $\pm 100mV$
Battery weak 2	battery empty level + 0.45V $\pm 100mV$	battery empty level + 0.5V $\pm 100mV$
Battery weak 3	battery empty level + 0.3V $\pm 100mV$	battery empty level + 0.3V $\pm 100mV$

### Current consumption

OPERATION MODE	DC-IN SUPPLY (4.5V)		BATT. SUPPLY (2.25V)	
	Powersave	ESP ON	Powersave	ESP ON
CD Play mode	80mA typ.	100mA typ.	100mA typ.	120mA typ.
CD Jump mode	220mA typ.	220mA typ.	300mA typ.	400mA typ.
CHARGE mode	n/a	300mA typ.	n/a	
Stand-by (excl. recharge)	30mA typ.		350 $\mu$ A typ.	

### Charge section (not on all versions)

Charge current	: 250mA $\pm 10\%$
Max. charge time ( $\mu$ P controlled)	: 7h
Temperature protection	: 50°C $\pm 5^\circ$ C

### Headphone out (measured with 16 $\Omega$ load, DBB/ESP off)

Output power (THD=10%)	
/17 version only	: 2x4mW (+2/-2dB)
all other versions	: 2x2mW (+2/-2dB)
Frequency response (1mW)	: 100Hz-20kHz within 6dB
S/N ratio (unwght)	: $\geq 76dB$ (80dB typ.)
S/N ratio (A-wght)	: $\geq 78dB$ (82dB typ.)
THD+N (1kHz, 1mW)	: $\leq 1\%$ (0.2% typ.)
Channel crosstalk(1kHz,w/o load)	: $\leq -40dB$ (-44dB typ.)
Channel unbalance (-40dB)	: $\leq 5dB$
Volume attenuation (1kHz)	: $\geq 60dB$

### Dynamic Bass Boost DBB

DBB STAGE	Frequency response		
	63kHz	1kHz	10kHz
DBB	+8dB $\pm 2dB$	0dB $\pm 2dB$	0dB $\pm 2dB$

### Measurement setup CD

Use Audio Signal disc SBC429

4822 397 30184

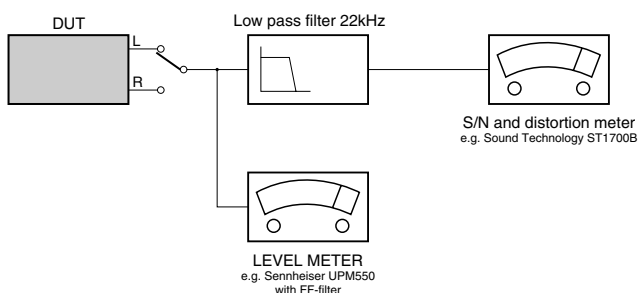
S/N and distortion meter  
e.g. Sound Technology ST1700B

## FEATURES

FEATURES OF CD-PORTABLE PRODUCT FAMILY FOCUS ESP	AX3200/00C	AX3200/00Z	AX3201/00C	AX3201/01	AX3201/05Z	AX3201/10	AX3202/00C	AX3205/10	AX3205/16	AX3211/17	AX3212/17	AX3214/17	AX3215/17
CD-RW COMPATIBILITY	●	●	●	●	●	●	●	●	●	●	●	●	●
ELECTRONIC SKIP PROTECTION	45s	45s	45s	45s	45s	45s	45s	45s	45s	45s	45s	45s	45s
ESP DRAM SIZE [Mbit]	16	16	16	16	16	16	16	16	16	16	16	16	16
HOLD / RESUME FUNCTION	●/●	●/●	●/●	●/●	●/●	●/●	●/●	●/●	●/●	●/●	●/●	●/●	●/●
DBB STAGES	1	1	1	1	1	1	1	1	1	1	1	1	1
ACOUSTIC FEEDBACK	●	●	●	●	●	●	●	●	●	●	●	●	●
PROGRAM MEMORY	30	30	30	30	30	30	30	30	30	30	30	30	30
RECHARGE NiCd / NiMH	--/--	--/--	--/--	--/--	--/--	--/--	●/●	--/--	--/--	--/--	--/--	--/--	--/--
BELT-CLIP	●	●	●	●	●	●	●	●	●	●	●	●	●
CORD REMOTE CONTROL	--	--	--	--	--	--	--	--	--	--	--	●	--
LINE / OPT. DIGITAL OUTPUT	--/--	--/--	--/--	--/--	--/--	--/--	--/--	--/--	--/--	--/--	--/--	--/--	--/--

## ACCESSORIES

ACCESSORIES FOR CD-PORTABLE PRODUCT FAMILY FOCUS ESP	AX3200	AX3200	AX3201				AX3202	AX3205		AX3211	AX3212	AX3214	AX3215
	/00c	/00z	/00c	/01	/05z	/10	/00c	/10	/16	/17	/17	/17	/17
AY3170/00 AC/DC Adaptor	4822 219 10617	O	O	X			X						
AY3170/02 AC/DC Adaptor	4822 219 10676				X			X					
AY3170/05 AC/DC Adaptor	4822 219 10672					X							
AY3170/10 AC/DC Adaptor	4822 219 10681					X		X					
AY3170/12 AC/DC Adaptor	4822 219 10671												
AY3170/17 AC/DC Adaptor	4822 219 10616									O	O	O	O
AY3266/00 Pouch (Neoprene)	3140 113 10360	O	O	O	O	O	O	O	O	O	O	O	O
AY3362/00 Rechargeable Batt. NiMH	3103 308 84120						X						
AY3464 HiFi Cord (3.5mm L-plug -cinch)	4822 320 11881	O	O	O	O	O	O	O	O	O	O	O	O
AY3501/00 Car Adaptor Cassette	4822 397 10059	O	O	O	O	O	O	X	X	O	O	O	X
AY3545/00 Car DC/DC Converter	4822 219 10033	O	O	O	O	O	O	X	X	O			
AY3545/17 Car DC/DC Converter	3140 118 32970										O	O	X
AY3768/00 Cord Remote Control	3140 118 50980									X			
HE205/77 Headphone	9082 100 00615	X	X	X	X	X	X	X	X				X
HE205/77s Headphone (S-plug)	9082 100 00616												
HL351/77 Headphone	9082 100 00639									X	X		X
HS383/77s Headphone (S-plug)	9082 100 01821											X	
BELT-CLIP	3103 304 70250	X	X	X	X	X	X	X	X	X	X	X	X

X...supplied with the set, O...optional available

# CONNECTIONS AND CONTROLS

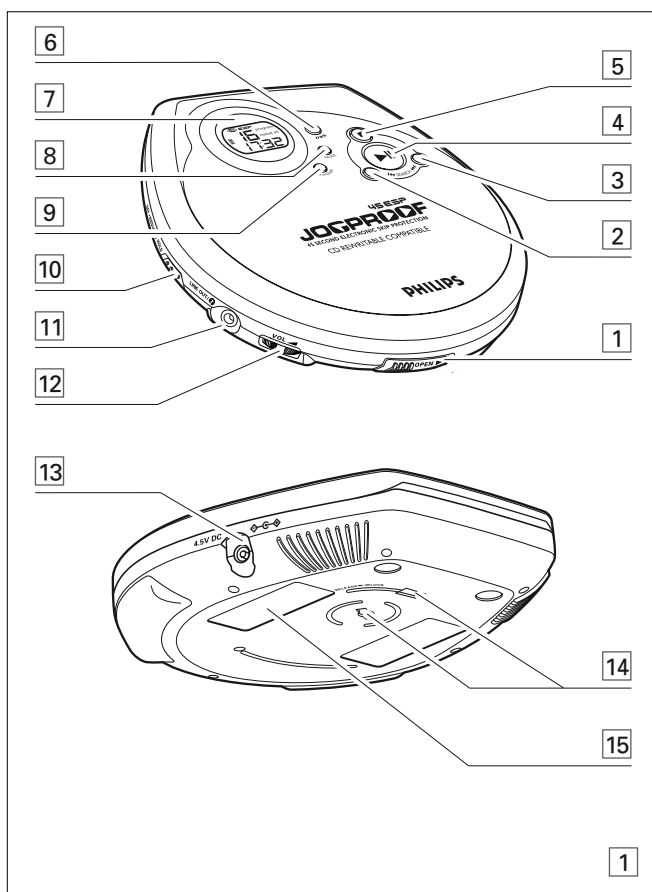

## QUICK START    MISE EN SERVICE RAPIDE    ENCENDIDO RAPIDO



## English    CONTROLS / POWER SUPPLY

### CONTROLS ( see figure 1 )

- 1 OPEN ► .....opens the CD lid
- 2 ◀◀ .....skips and searches CD tracks backwards
- 3 ▶▶ .....skips and searches CD tracks forwards
- 4 ►|| .....switches the player on, starts or pauses CD play
- 5 ■ .....stops CD play, clears a program or switches the player off
- 6 DBB .....switches the bass enhancement on and off. This button also switches acoustic feedback (the beep) on/off when it is pressed for more than 2 seconds
- 7 .....display
- 8 MODE .....selects the different playing possibilities: **shuffle**, **shuffle repeat all**, **repeat**, **repeat all** and **SCAN**
- 9 PROGRAM .....programs tracks and reviews the program
- 10 RESUME .....stores the last position of a CD track played
- HOLD.....locks all buttons
- OFF.....switches RESUME and HOLD off
- 11 LINE OUT/🎧.....3.5 mm headphone socket, socket to connect the player to another audio input of an additional appliance, remote control socket (not on all versions)
- 12 VOL ◀ .....adjusts the volume
- 13 4.5V DC.....socket for external power supply
- 14 .....belt clip holder
- 15 .....typeplate

### Batteries (supplied or optionally available)

You can use the following batteries with this CD-player:

- normal batteries type **LR6**, **UM3** or **AA** (preferably Philips), or
- alkaline batteries type **LR6**, **UM3** or **AA** (preferably Philips).

Notes:– Old and new or different types of batteries should not be combined.  
– Remove batteries if they are empty or if the player is not going to be used for a long time.

### Inserting batteries

- 1 Push OPEN ► to open the CD lid.
- 2 Open the battery compartment and insert either 2 normal or alkaline batteries, or the rechargeable NiMH battery AY3362 (if supplied).

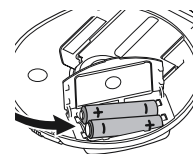

### Battery indication

The approximate power level of your batteries is shown in the display.

- 🔋 Battery full
- 🔋 Battery two-thirds full
- 🔋 Battery one-third full
- 🔋 Battery dead or empty. When the batteries are dead or empty, the symbol flashes, **bAtt** is displayed, and the beep tone sounds repeatedly.



### Average playing time of batteries under normal conditions

Battery type	ESP on	Power Save
Normal	5 hours	6 hours
Alkaline	16 hours	20 hours
Rechargeable ECO-PLUS NiMH battery	7 hours	9 hours

**Batteries contain chemical substances, so they should be disposed of properly.**

*This set complies with the radio interference requirements of the European Union.*

# INSTRUCTION FOR USE

## POWER SUPPLY / GENERAL INFORMATION

### ECO-PLUS NiMH battery information (for versions supplied with the rechargeable ECO-PLUS NiMH battery AY 3362)

Recharging works only on players supplied with the rechargeable ECO-PLUS NiMH battery AY 3362.

#### Recharging the ECO-PLUS NiMH battery on board

- 1 Insert the rechargeable ECO-PLUS NiMH battery AY 3362.
- 2 Connect the mains adapter to the 4.5V DC socket of the player and then to the wall socket.  
→  is pulsing.

- Recharging stops after a maximum of 7 hours, or when you start playback.

- 3 When the battery is fully recharged,  and **FULL** appears in the display.



*Notes:*

- It is normal for the batteries to become warm during recharging.
- If the batteries become too warm, recharging will be interrupted for approximately 30 minutes and **Hot** is displayed.
- To ensure proper recharging on board, take care that contacts are clean.
- Use only the ECO-PLUS NiMH battery AY 3362.

#### Handling instructions

- Recharging already charged or half-charged batteries will shorten their lifetime. We therefore recommend that you let the rechargeable ECO-PLUS NiMH battery run till it is completely empty before you recharge it.
- To avoid a short circuit, do not let the battery touch any metal object.
- If the battery becomes empty soon after recharging, then either its contacts are dirty or it has reached the end of its lifetime.

### Mains adapter (supplied or optionally available)

Use only the AY 3170 adapter (4.5 V / 300 mA direct current, positive pole to the center pin). Any other product may damage the player.

- 1 Make sure the local voltage corresponds to the power adapter's voltage.
- 2 Connect the power adapter to the 4.5V DC socket of the player and to the wall socket.

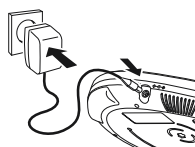

*Note:* Always disconnect the adapter when you are not using it.

### Belt Clip (not on all versions)

- 1 To attach the belt clip to the CD-player, position the shaped grip (found on the back of the belt clip) so that it fits into the belt clip hole of the CD-player.
- 2 Turn the clip to **LOCK** as indicated on the set.
- 3 To detach, gently lift the belt clip and turn to **RELEASE** as indicated on the set.

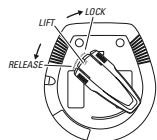
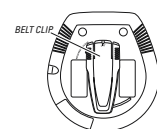

### Environmental information

- All redundant packing material has been omitted. We have done our utmost to make the packaging easily separable into two mono materials: cardboard (box) and polyethylene (bags, protective foam sheet).
- Your set consists of materials which can be recycled if disassembled by a specialized company. Please observe the local regulations regarding the disposal of packing materials, exhausted batteries and old equipment.

## GENERAL INFORMATION

### CD player and CD handling

- Do not touch the lens (A) of the CD player.
- Do not expose the unit, batteries or CDs to humidity, rain, sand or excessive heat (caused by heating equipment or direct sunlight).
- You can clean the CD player with a soft, slightly dampened, lint-free cloth. Do not use any cleaning agents as they may have a corrosive effect.
- To clean the CD, wipe it in a straight line from the center toward the edge using a soft, lint-free cloth. A cleaning agent may damage the disc! Never write on a CD or attach a sticker to it.
- The lens may cloud over when the unit is moved suddenly from cold to warm surroundings. Playing a CD is not possible then. Leave the CD player in a warm environment until the moisture has evaporated.
- Active mobile phones in the vicinity of the CD player may cause malfunctions.
- Avoid dropping the unit as this may cause damage.

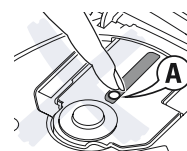

### Headphones HE205

- Connect the supplied headphones to the LINE OUT/🔊 socket of the player.

*Note:* LINE OUT/🔊 can also be used for connecting this set to your HiFi system. To adjust the sound and volume, use the controls on the connected audio equipment and on the CD player.

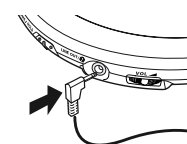

### IMPORTANT!

**Hearing safety:** Do not play your headphones at a high volume. Hearing experts advise that continuous use at high volume can permanently damage your hearing.

**Traffic safety:** Do not use headphones while driving a vehicle. It may create a hazard and it is illegal in many countries. Even if your headphones are an open-air type designed to let you hear outside sounds, do not turn up the volume so high that you cannot hear what is going on around you.

### In-car use (connections supplied or optionally available)

Only use the AY 3545 (4822 219 10033) or AY 3548 (3140 118 71890) car voltage converter (4.5 V DC, positive pole to the centre pin) and the AY 3501 car adapter cassette. Any other product may damage the set.

- 1 Put the set on a horizontal, vibration-free and stable surface. Make sure it is in a safe place, where the set is neither a danger nor an obstacle to the driver and the passengers.
  - 2 Plug the voltage converter into the cigarette lighter socket (**only for 12 V car battery, negative grounding**), then connect the wired end with 4.5V DC input socket on the set.
  - 3 If necessary, clean the cigarette lighter socket to obtain a good electrical contact.
  - 4 Turn down the volume and connect the adapter cassette plug to LINE OUT/🔊 on the set.
  - 5 Carefully insert the adapter cassette into the car radio's cassette compartment.
  - 6 Make sure the cord does not hinder your driving.
  - 7 Decrease the volume on the set if necessary. Start playback on the set and adjust the sound with the car radio controls.
- **Always remove the voltage converter from the cigarette lighter socket when the set is not in use.**

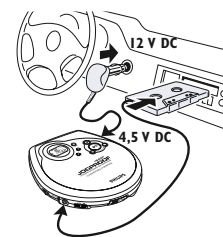

*Note:* If your car radio has a LINE IN socket, it is better to use it for the car radio connection instead of the adapter cassette. Connect the signal lead to this LINE IN socket and to LINE OUT/🔊 on the set.

# INSTRUCTION FOR USE

## CD PLAY

### Playing a CD

This CD-player can play all kinds of **Audio Discs** such as CD-Recordables and CD-Rewritables. Do not try to play a CD-ROM, CDi, VCD, DVD or computer CD.

- 1 Push the OPEN ► slider to open the player.
- 2 Insert an audio CD, printed side up, by pressing the CD onto the hub.
- 3 Close the player by pressing the lid down.
- 4 Press ►|| to switch the player on and start playback.
  - The current track number and elapsed playing time are displayed.
- You can pause playback by pressing ►||.
  - The time at which playback was paused starts flashing.
- You can continue playback by pressing ►|| again.
- 5 Press ■ to stop playback.
  - The total number of tracks and the total playing time of the CD are displayed.
- 6 Press ■ again to switch the player off.
- To remove the CD, hold it by its edge and press the hub gently while lifting the CD.

*Note: If there is no activity, the set will automatically switch off after a while to save energy.*

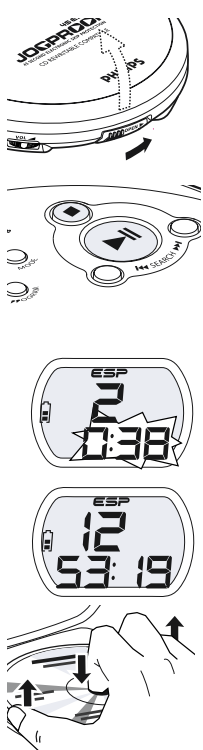

### Playback information

- If a CD-Recordable (CD-R) or a CD-Rewritable (CD-RW) is not recorded properly, **SEL** is displayed, indicating that the CD has not been finalized. In that case, use FINALIZE on your CD recorder to complete the recording.
- When playing a CD-Rewritable (CD-RW), please note that it takes 3–15 seconds after pressing ►|| for sound reproduction to start.
- Playback will stop if you open the CD lid.
- While the CD is read, **SEL** flashes in the display.

### Volume and bass

#### Volume adjustment

- Adjust the volume by using VOL ▲.

#### Bass adjustment

- Press DBB to switch the bass enhancement on or off.
  - **DBB** is shown if the bass enhancement is activated.

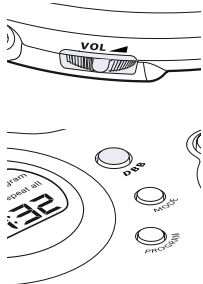

### Remote control (supplied or optionally available)

Use the AY 3768 cord remote control. The buttons on the remote control have the same functions as the corresponding buttons on the set.

- 1 Press ■ twice to switch off the set.
- 2 Firmly connect the remote control to LINE OUT/⏏ on the set.
- 3 Adjust the volume VOL ▲ on the CD player and remote control.

## FEATURES

### Selecting a track and searching

#### Selecting a track during playback

- Briefly press ◀◀ or ▶▶ once or several times to skip to the current, previous or next track.
  - Playback continues with the selected track, and the track's number is displayed.



#### Selecting a track when playback is stopped

- 1 Briefly press ◀◀ or ▶▶ once or several times to select the desired track. The track number is displayed.
- 2 Press ►|| to start CD play.
  - Playback starts with the selected track.

#### Searching for a passage during playback

- 1 Keep ◀◀ or ▶▶ pressed to find a particular passage in a backward or forward direction.
  - Searching starts while playback continues at low volume. After 2 seconds the search speeds up.
- 2 Release the button when you reach the desired passage.
  - Playback continues from this position.

*Notes:* – If the player is in SCAN mode (see MODE chapter), searching is not possible.  
– In shuffle, shuffle repeat all or repeat mode (see MODE chapter), or while playing a program, searching is only possible within the particular track.

### Programming track numbers

You can store up to 30 tracks to play in a program. A single track may be stored more than once in the program.

- 1 While playback is stopped, select a track with ◀◀ or ▶▶.
- 2 Press PROGRAM to store the track.
  - **program** lights up; the track number programmed and **P** with the total number of stored tracks are displayed.
- 3 Select and store all desired tracks in this way.
- 4 Press ►|| to start playback of your selected tracks.
  - **program** is shown and playback starts.

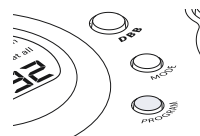

- You can review the program by pressing PROGRAM for more than 2 seconds.
  - The display shows all the stored tracks in sequence.

*Notes:* – If you press PROGRAM and there is no track selected, **SEL** is displayed.  
– If you try to store more than 30 tracks, **FULL** is displayed.

#### Clearing the program

- While playback is stopped, press ■ to clear program.
  - **SEL** is displayed once, **program** goes off, and the program is cleared.



*Note:* The program will also be cleared if the power supply is interrupted, or if the CD-player lid is opened, or if the set switches off automatically.



# INSTRUCTION FOR USE

## FEATURES

### Selecting different playing possibilities—MODE

It is possible to play tracks in random order, to repeat a single track or the entire CD, and to play the first few seconds of each track.

1 Press MODE during playback as often as required in order to activate one of the following 'modes'. The active mode is shown in the display.

→ **shuffle** : All tracks of the CD are played in random order until all of them have been played once.

→ **shuffle repeat all** : All tracks of the CD are played repeatedly in random order.

→ **repeat** : The current track is played repeatedly.

→ **repeat all** : The entire CD is played repeatedly.

→ **5 C R R** : The first 10 seconds of each of the remaining tracks are played in sequence.

2 Playback starts in the chosen mode after 2 seconds.

- To return to normal playback, press MODE repeatedly until the display shows no active modes.

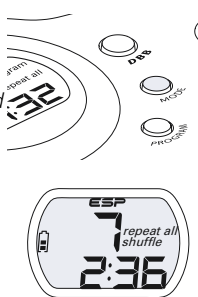

### ESP / Power Save Mode

With a conventional portable CD-player you might have experienced that the music stopped e.g. when you were jogging. The **ELECTRONIC SKIP PROTECTION** prevents loss of sound caused by light vibrations and shocks. Continuous playback is ensured. However ESP does not prevent playback interruptions during vigorous running. It also does not protect the unit against any damage caused by dropping! On this set ESP is default on. It is possible to set ESP off and enter the Power Save mode. The Power Save mode helps to extend battery lifetime for longer playback.

- Press MODE for more than 2 seconds.
  - ESP disappears. Power save mode is now activated.
- Press MODE again for more than 2 seconds.
  - ESP is displayed once

ESP on → Power Save → ESP on

### RESUME and HOLD

You can interrupt playback and continue (even after an extended period of time) from the position where playback stopped (RESUME) and you can lock all buttons of the set so that no action will be executed (HOLD). Use the RESUME—HOLD—OFF slider for these functions.

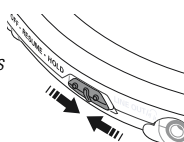

#### RESUME – continuing from where you have stopped

1 Switch the slider to RESUME during playback to activate RESUME.

→ **resume** is shown.

2 Press ■ whenever you want to stop playback.

3 Press ►|| whenever you want to resume playback.
 

- **resume** is shown and playback continues from where you have stopped.



- To deactivate RESUME, switch the slider to OFF.
  - **resume** goes off.

#### HOLD – locking all buttons

You can lock the buttons of the set by switching the slider to HOLD. Now, when a key is pressed, no action will be executed. This is of use, for example, when transporting the player in a bag. With HOLD activated, you can avoid accidental activation of other functions.

1 Switch the slider to HOLD to activate HOLD.

→ All buttons are locked. **HOLD** is shown when you press any button. If the set is switched off, **hold** will be shown only when ►|| is pressed.



2 To deactivate HOLD, switch the slider to OFF.

Note: If you deactivate HOLD by switching the slider to RESUME, you will be activating the RESUME function.

## TROUBLESHOOTING

### Troubleshooting

**WARNING:** Under no circumstances should you try to repair the set yourself as this will invalidate the warranty. If a fault occurs, first check the points listed, before taking the unit for repair. If you are unable to solve a problem by following these hints, consult your dealer or service center.

#### The CD player has no power, or playback does not start

- Check that your batteries are not dead or empty, that they are inserted correctly, that the contact pins are clean.
- Your adapter connection may be loose. Connect it securely.
- For in-car use, check that the car ignition is on. Also check player's batteries.

#### The indication **ESP** is displayed

- Check that the CD is clean and correctly inserted (label-side upward).
- If your lens has steamed up, wait a few minutes for this to clear.

#### The indication **5 C R R** is displayed

- CD-RW (CD-R) was not recorded properly. Use FINALIZE on your CD-recorder.

#### The indication **HOLD** is on and/or there is no reaction to controls

- If HOLD is activated, then deactivate it.
- Electrostatic discharge. Disconnect power or remove batteries for a few seconds.

#### The CD skips tracks

- The CD is damaged or dirty. Replace or clean the CD.
- RESUME, SHUFFLE or PROGRAM is active. Switch off whichever is on.

### Troubleshooting

#### No sound or bad sound quality.

- PAUSE might be active. Press ►||.
- Loose, wrong or dirty connections. Check and clean connections.
- Volume might not be appropriately adjusted. Adjust the volume.
- Strong magnetic fields. Check player's position and connections. Also keep away from active mobile phones.
- For in-car use, check that the cassette adapter is inserted correctly, that the car cassette player's playback direction is correct (press autoreverse to change), and that the cigarette lighter jack is clean. Allow time for temperature change. **operation.**

### CAUTION

Use of controls or adjustments or performance of procedures other than herein may result in hazardous radiation exposure or other unsafe

## SAFETY & WARNINGS

### ⒼⒷ WARNING

All ICs and many other semiconductors are susceptible to electrostatic discharges (ESD). Careless handling during repair can reduce life drastically.

When repairing, make sure that you are connected with the same potential as the mass of the set via a wristband with resistance. Keep components and tools at this potential.

### ⒻⒻ ATTENTION

Tous les IC et beaucoup d'autres semi-conducteurs sont sensibles aux décharges statiques (ESD). Leur longévité pourrait être considérablement écourtée par le fait qu'aucune précaution n'est prise à leur manipulation.

Lors de réparations, s'assurer de bien être relié au même potentiel que la masse de l'appareil et enfilez le braceleterti d'une résistance de sécurité

Veiller à ce que les composants ainsi que les outils que l'on utilise soient également à ce potentiel.

### ESD



### ⒻⒻ WARNING

Alle ICs und viele andere Halbleiter sind empfindlich gegenüber elektrostatischen Entladungen (ESD). Unsorgfältige Behandlung im Reparaturfall kann die Lebensdauer drastisch reduzieren.

Sorgen Sie dafür, daß Sie im Reparaturfall über ein Pulsarmband mit Widerstand mit dem Massepotential des Gerätes verbunden sind.

Halten Sie Bauteile und Hilfsmittel ebenfalls auf diesem Potential.

### ⒼⒻ WAARSCHUWING

Alle IC's en vele andere halfgeleiders zijn gevoelig voor electrostatische ontladingen (ESD).

Onzorgvuldig behandelen tijdens reparatie kan de levensduur drastisch doen verminderen. Zorg ervoor dat u tijdens reparatie via een polsband met weerstand verbonden bent met hetzelfde potentiaal als de massa van het apparaat.

Houd componenten en hulpmiddelen ook op ditzelfde potentiaal.

### ⒻⒻ AVVERTIMENTO

Tutti IC e parecchi semi-conduttori sono sensibili alle scariche statiche (ESD).

La loro longevità potrebbe essere fortemente ridatta in caso di non osservazione della più grande cauzione alla loro manipolazione. Durante le riparazioni occorre quindi essere collegato allo stesso potenziale che quello della massa delapparecchio tramite un braccialetto a resistenza.

Assicurarsi che i componenti e anche gli utensili con quali si lavora siano anche a questo potenziale.

### ⒼⒷ AVAILABLE ESD PROTECTION EQUIPMENT :

<b>anti-static table mat</b>	large 1200x650x1.25mm	4822 466 10953
	small 600x650x1.25mm	4822 466 10958
<b>anti-static wristband</b>		4822 395 10223
<b>connection box</b>	(3 press stud connections, 1MΩ)	4822 320 11307
<b>extendible cable</b>	(2m, 2MΩ, to connect wristband to connection box)	4822 320 11305
<b>connecting cable</b>	(3m, 2MΩ, to connect table mat to connection box)	4822 320 11306
<b>earth cable</b>	(1MΩ, to connect any product to mat or to connection box)	4822 320 11308
<b>KIT ESD3</b>	(combining all 6 prior products - small table mat)	4822 310 10671
<b>wristband tester</b>		4822 344 13999

### ⒼⒷ

Safety regulations require that the set be restored to its original condition and that parts which are identical with those specified be used.

Safety components are marked by the symbol

### ⒻⒻ

Les normes de sécurité exigent que l'appareil soit remis à l'état d'origine et que soient utilisées les pièces de rechange identiques à celles spécifiées.

Les composants de sécurité sont marqués

## SAFETY



### ⒻⒻ

Bei jeder Reparatur sind die geltenden Sicherheitsvorschriften zu beachten. Der Originalzustand des Gerätes darf nicht verändert werden. Für Reparaturen sind Originalersatzteile zu verwenden.

Sicherheitsbauteile sind durch das Symbol

### ⒼⒻ

Veiligheidsbepalingen vereisen, dat het apparaat in zijn oorspronkelijke toestand wordt teruggebracht en dat onderdelen, identiek aan de gespecificeerde, worden toegepast. De Veiligheidsonderdelen zijn aangeduid met het symbool

### ⒻⒻ

Le norme di sicurezza estigono che l'apparecchio venga rimesso nelle condizioni originali e che siano utilizzati i pezzi di ricambio identici a quelli specificati.

Componenti di sicurezza sono marcati con

### ⒼⒷ

**DANGER:** Invisible laser radiation when open. AVOID DIRECT EXPOSURE TO BEAM.



### ⒻⒻ Varning !

Osynlig laserstrålning när apparaten är öppnad och spårren är urkopplad. Betrakta ej strålen.

### ⒻⒻ Advarsel !

Usynlig laserstrålning ved åbning når sikkerhedsafbrydere er ude af funktion. Undgå udsættelse for strålning.

### ⒻⒻ Varoitus !

Avatussa laitteessa ja suojalukituksen ohitettaessa olet alttiina näkymättömälle laserisäteilylle. Älä katso säteeseen !

### ⒼⒷ

After servicing and before returning the set to customer perform a leakage current measurement test from all exposed metal parts to earth ground, to assure no shock hazard exists.

The leakage current must not exceed 0.5mA.

### ⒻⒻ

"Pour votre sécurité, ces documents doivent être utilisés par des spécialistes agréés, seuls habilités à réparer votre appareil en panne".



## SERVICE HINTS

### REPAIR POSITION COPPERSIDE

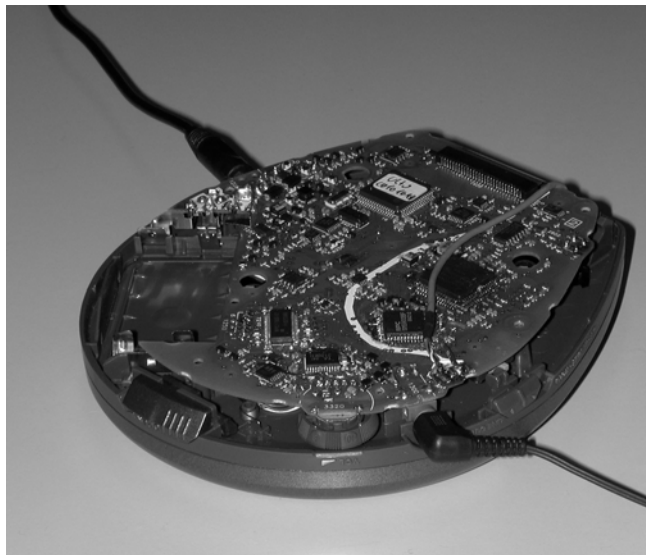

To get access to the copperside of the printed board assembly proceed as follows:

- 1.Remove the bottom screws(6x)
- 2.Lift the bottom -cabinet
- 3.Supply the unit via external DC-socket
- 4.Take care that the door switch is closed during measurements

### REPAIR POSITION COMPONENTSIDE

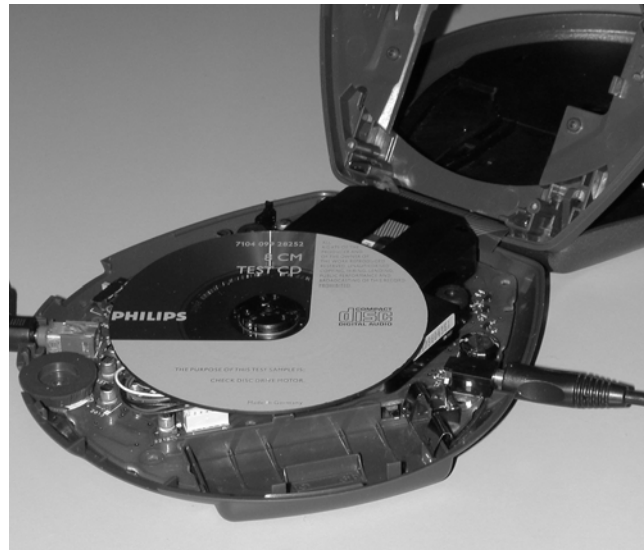

To get access to the componentside of the printed board assembly proceed as followed:

- 1.Remove the bottom screws(6x)
- 2.Open the CD-door
- 3.Lift the top-cabinet and put it backwards on the table
- 4.Supply the unit via the external DC-socket
- 5.Take care that the door switch is closed during measurements

### DISMANTLING THE CD-DOOR

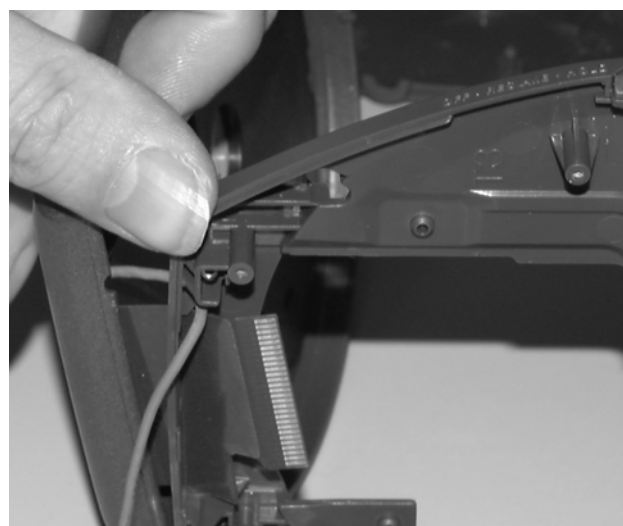
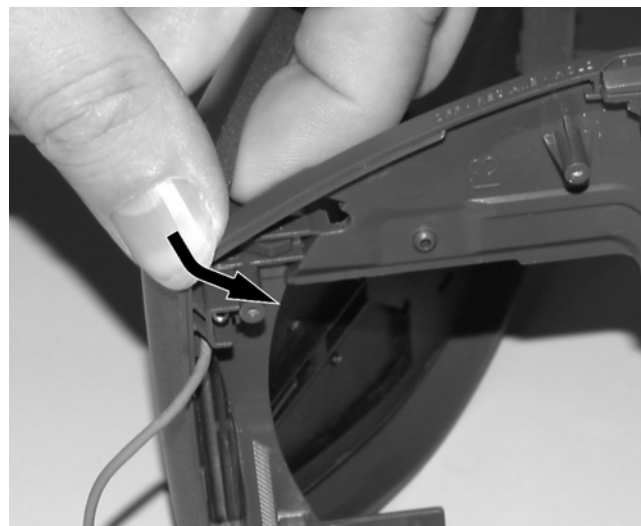

To dismantle the CD-door proceed as follows:

- 1.Dismantle bottom and printed board/drive assembly
- 2.Disconnect membrane keyboard  
(flex-foil connector on copperside of printed board)
- 3.Bend the cabinet rightwards downwards as indicated in the picture above

Remark:Do not use screwdrivers or tools like that.  
Sharp edges could damage hinge or cabinet part.

## HANDLING CHIP COMPONENTS

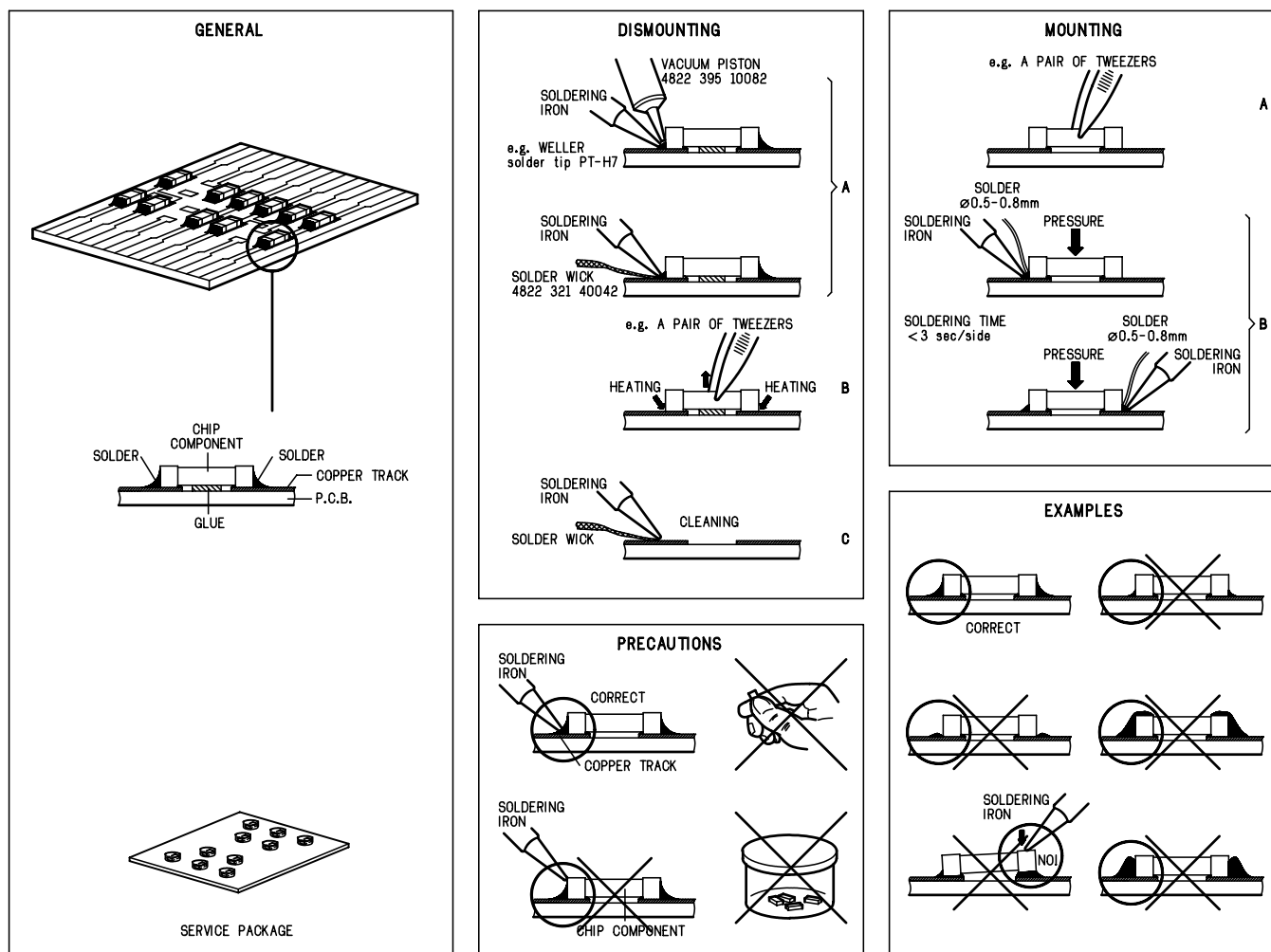

## SERVICE TOOLS

**Audio signal disc SBC429**

4822 397 30184

**Playability test disc SBC444**

4822 397 30245

**Test disc 5** (disc without errors) + **Test disc 5A** (disc with dropout errors  
black spots and fingerprints) **SBC426/ SBC426A**

4822 397 30096

## ESD PROTECTION EQUIPMENT

**Anti-static table mat** large 1200x650x1.25mm  
small 600x650x1.25mm

4822 466 10953

4822 466 10958

**Anti-static wristband**

4822 395 10223

**Connection box** (3press stud connections, 1MΩ)

4822 320 11307

**Extendible cable** (2m, 2MΩ, to connect wristband to connection box)

4822 320 11305

**Connecting cable** (3m, 2MΩ, to connect table mat to connection box)

4822 320 11306

**Earth cable** (1MΩ, to connect any product to mat or to connection box)

4822 320 11308

**KIT ESD3** (combining all 6 prior products - small table mat)

4822 310 10671

**Wristband tester**

4822 344 13999

## PIN DESCRIPTION OF INTEGRATED CIRCUITS

### MN662786SB – SIGNAL PROCESSING IC

Pin	Name	I/O	Description
1	DRVDD	I	Power supply for DRAM interface (Pin 2 to 19, and 80)
2	D0	I/O	DRAM data I/O signal 0
3	D1	I/O	DRAM data I/O signal 1
4	NWE	O	DRAM write enable signal
5	NRAS	O	DRAM RAS control signal
6	D2	I/O	DRAM data I/O signal 2
7	D3	I/O	DRAM data I/O signal 3
8	NCAS0	O	DRAM CAS control signal 0
9	NCAS1	O	DRAM CAS control signal 1
10	A8	O	DRAM address signal 8
11	A7	O	DRAM address signal 7
12	A6	O	DRAM address signal 6
13	A5	O	DRAM address signal 5
14	A4	O	DRAM address signal 4
15	A9	O	DRAM address signal 9
16	A0	O	DRAM address signal 0
17	A1	O	DRAM address signal 1
18	A2	O	DRAM address signal 2
19	A3	O	DRAM address signal 3
20	DVSS2	I	Ground for digital circuits
21	DVDD2	I	Power supply for digital circuits
22	SPOUT	O	Spindle motor drive signal output (Absolute value output)
23	TRVP	O	Traverse drive output (+side output)
24	TRVM	O	Traverse drive output (-side output)
25	TRP	O	Traverse drive output (+side output)
26	TRM	O	Traverse drive output (-side output)
27	FOP	O	Focus drive output (+side output)
28	FOM	O	Focus drive output (-side output)
29	IOVDD1	I	I/O power supply
30	TBAL	O	Tracking balance adjustment output
31	FBAL	O	Focus balance adjustment output
32	FE	I	Focus error signal input (Analog input)
33	TE	I	Tracking error signal input (Analog input)
34	RFENV	I	RF envelope signal input (Analog input)
35	OFT	I	Off-track signal input H: Off track
36	NRFDET	I	RF detection signal input L: Detect
37	BDO	I	Dropout signal input H: Dropout
38	LDON	O	Laser ON signal output H: ON
39	ARF	I	RF signal input
40	IREF	I	Reference current input
41	ADPVCC	I	A/D converter reference voltage input (Analog input)
42	DSLFL	O	DSL loop filter
43	DRF	I	DSL bias
44	PLLF	O	PLL loop filter
45	VCOF	O	Jitter-free VCO loop filter
46	AVDD2	I	Power supply for analog circuits (For DSL, PLL, VCOF, A/D converter, and D/A converter)
47	AVSS2	I	Ground for analog circuits (For DSL, PLL, VCOF, A/D converter, and D/A converter)
48	OUTL	O	L-ch audio output
49	AVSS1	I	Ground for analog circuit (For audio output stage)
50	OUTR	O	R-ch audio output
51	AVDD1	I	Power supply for analog circuits (For audio output stage)
52	FSEL	I	Noise filter for microcontroller interface ON/OFF selection input L: ON H: OFF
53	TMOD1	I	Test input pin Normal: L
54	TMOD2	I	Test input pin Normal: L
55	*FLAG	O	Flag signal output
56	*IPFLAG	O	Interpolation flag signal output H: Interpolation
57	*EXT0	I/O	Expansion I/O port 0
58	*EXT1	I/O	Expansion I/O port 1
59	IOVDD2	I	I/O power supply
60	TX	O	Digital audio interface signal output
61	MCLK	I	Microcontroller command clock signal input (Latches the data at a rising edge)
62	MDATA	I	Microcontroller command data signal input
63	MLD	I	Microcontroller command load signal input L: Load
64	*BLKCK	O	Subcode block clock signal output f=75 Hz (Normal-speed playback)
65	PWMSEL	I/O	PWM output mode selection input L: Direct H: 3-state
66	SMCK	O	4.236-MHz/8.4672-MHz clock signal output
67	DMUTE	I/O	Muting input H: Mute
68	STAT	O	Status signal output
69	NRST	I	Reset input L: Reset

Pin	Name	I/O	Description
70	*SPPOL	O	Spindle motor drive signal output (Polarity output)
71	PMCK	O	88.2-KHz clock signal output
72	*NCLDCK	O	Frame sync signal output f=7.35kHz (Normal-speed playback)
73	*SUBC	O	Subcode serial output
74	*SBCK	I	Subcode serial output clock input
75	NTEST	I	Test input pin Normal: H
76	X2	O	Crystal oscillator output pin f=16.9344 MHz
77	X1	I	Crystal oscillator input pin f=16.9344 MHz
78	DVSS1	I	Ground for digital circuits
79	DVDD1	I	Power supply for digital circuits
80	*EXT2	I	Expansion I/O part 2

### AN8789FB– SILICON MONOLITHIC BIPOLAR IC

Pin	Name	Description
1	VSEN	Empty detection input
2	PVCC1	Power supply
3	RESET	Reset output
4	DED	Dead time input
5	OUT	CD/DC converter output
6	FB	Error amplifier output
7	IN	Error amplifier input
8	SPRO	Short-circuit protection input
9	CT	Triangular wave oscillation
10	AREF	1/2 AVDD output
11	CRIP	Ripple rejection capacitor
12	SVCC	Power supply
13	N.C.	Not connected
14	AVDD	Ripple filter output
15	DRVDD	Power supply
16	VREF	1/2 VDCC input
17	INFO	Driver input
18	INTR	Driver input
19	LDON	Driver ON/OFF control
20	INSP	Driver input
21	PC	Driver IN/OFF control
22	INTV	Driver input
23	TRVSTOP	Driver ON/OFF control
24	TR-	Driver output
25	TR+	Driver output
26	FO-	Driver output
27	FO+	Driver output
28	PGND	Ground
29	SP+	Driver output
30	SP-	Driver output
31	TV+	Driver output
32	TV-	Driver output
33	ICONT	Charge current setting
34	MRST	Muting reset output
35	EMP	Empty detection output
36	Vc	Driver supply voltage
37	TB	PWM circuit output
38	CLK	External sync input
39	START	Start oscillation starting input
40	POWER	Power ON/OFF
41	PVCC2	Power supply
42	IOUT	Charging and battery detection
43	SGND	Ground
44	PWMG	PWM loop gain control

# MN101C39C-399 - MICROCOMPUTER BLOCK DIAGRAM

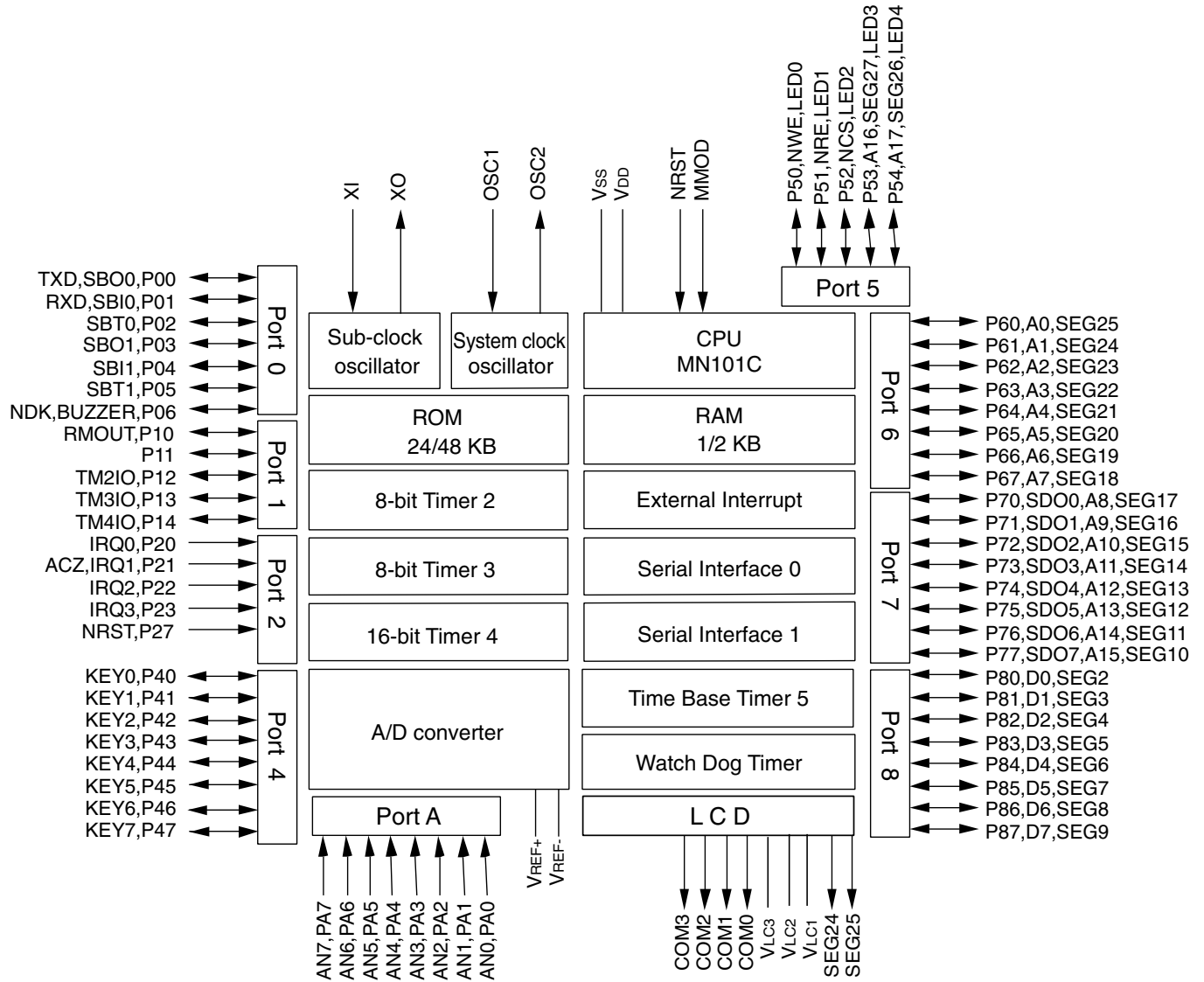

## PIN DESCRIPTION OF MN101C39C-399

## Pin Specification (1/2)

Pins	Special Functions	I/O	Direction Control	Pin Control	Functions Description
P00	SBO0 TXD	in/out	P0DIR0	P0PLU0	SBO0 : Serial Interface 0 transmission data output TXD : UART transmission data output
P01	SBI0 RXD	in/out	P0DIR1	P0PLU1	SBI0 : Serial Interface 0 reception data input RXD : UART reception data input
P02	SBT0	in/out	P0DIR2	P0PLU2	SBT0 : Serial Interface 0 clock I/O
P03	SBO1	in/out	P0DIR3	P0PLU3	SBO1 : Serial Interface 1 transmission data output
P04	SBI1	in/out	P0DIR4	P0PLU4	SBI1 : Serial Interface 1 reception data input
P05	SBT1	in/out	P0DIR5	P0PLU5	SBT1 : Serial Interface 1 clock I/O
P06	NDK BUZZER	in/out	P0DIR6	P0PLU6	NDK : Data acknowledgement signal BUZZER : Buzzer output
P10	RMOUT	in/out	P1DIR0	P1PLU0	RMOUT : Remote control carrier output
P11		in/out	P1DIR1	P1PLU1	
P12	TM2IO	in/out	P1DIR2	P1PLU2	TM2IO : Timer 2 I/O
P13	TM3IO	in/out	P1DIR3	P1PLU3	TM3IO : Timer 3 I/O
P14	TM4IO	in/out	P1DIR4	P1PLU4	TM4IO : Timer 4 I/O
P20	IRQ0	in	-	P2PLU0	IRQ0 : External interrupt 0
P21	IRQ1 ACZ	in	-	P2PLU1	IRQ1 : External interrupt 1 ACZ : Zero-cross input
P22	IRQ2	in	-	P2PLU2	IRQ2 : External interrupt 2
P23	IRQ3	in	-	P2PLU3	IRQ3 : External interrupt 3
P27	NRST	in	-	-	NRST : Reset
P40	KEY 0	in/out	P4DIR0	P4PLU0	KEY0 : KEY interrupt input 0
P41	KEY 1	in/out	P4DIR1	P4PLU1	KEY1 : KEY interrupt input 1
P42	KEY 2	in/out	P4DIR2	P4PLU2	KEY2 : KEY interrupt input 2
P43	KEY 3	in/out	P4DIR3	P4PLU3	KEY3 : KEY interrupt input 3
P44	KEY 4	in/out	P4DIR4	P4PLU4	KEY4 : KEY interrupt input 4
P45	KEY 5	in/out	P4DIR5	P4PLU5	KEY5 : KEY interrupt input 5
P46	KEY 6	in/out	P4DIR6	P4PLU6	KEY6 : KEY interrupt input 6
P47	KEY 7	in/out	P4DIR7	P4PLU7	KEY7 : KEY interrupt input 7
P50	NWE LED0	in/out	P5DIR0	P5PLU0	NWE : Write enable signal LED0 : LED driving pin 0
P51	NRE LED1	in/out	P5DIR1	P5PLU1	NRE : Read enable signal LED1 : LED driving pin 1
P52	NCS LED2	in/out	P5DIR2	P5PLU2	NCS : Chip select signal LED2 : LED driving pin 2
P53	A16 LED3	in/out	P5DIR3	P5PLU3	A16 : Address output (bp16) LED3 : LED driving pin 3
P54	SEG27 LED4	in/out	P5DIR4	P5PLU4	SEG27 : LCD segment output 27 LED : LED driving pin 4
	SEG26				SEG26 : LCD segment output 26
P60	A0 SEG25	in/out	P6DIR0	P6PLU0	A0 : Address output (bp0) SEG25 : LCD segment output 25
P61	A1 SEG24	in/out	P6DIR1	P6PLU1	A1 : Address output (bp1) SEG24 : LCD segment output 24
P62	A2 SEG23	in/out	P6DIR2	P6PLU2	A2 : Address output (bp2) SEG23 : LCD segment output 23
P63	A3 SEG22	in/out	P6DIR3	P6PLU3	A3 : Address output (bp3) SEG22 : LCD segment output 22
P64	A4 SEG21	in/out	P6DIR4	P6PLU4	A4 : Address output (bp4) SEG21 : LCD segment output 21
P65	A5 SEG20	in/out	P6DIR5	P6PLU5	A5 : Address output (bp5) SEG20 : LCD segment output 20
P66	A6 SEG19	in/out	P6DIR6	P6PLU6	A6 : Address output (bp6) SEG19 : LCD segment output 19
P67	A7 SEG18	in/out	P6DIR7	P6PLU7	A7 : Address output (bp7) SEG18 : LCD segment output 18



### Pin Specification (2/2)

Pins	Special Functions	I/O	Direction Control	Pin Control	Functions Description
P70	A8 SEG17 SDO0	in/out	P7DIR0	P7PLUD0	A8 : Address output (bp8) SEG17 : LCD segment output 17 SDO0 : Synchronous output 0
P71	A9 SEG16 SDO1	in/out	P7DIR1	P7PLUD1	A9 : Address output (bp9) SEG16 : LCD segment output 16 SDO1 : Synchronous output 1
P72	A10 SEG15 SDO2	in/out	P7DIR2	P7PLUD2	A10 : Address output (bp10) SEG15 : LCD segment output 15 SDO2 : Synchronous output 2
P73	A11 SEG14 SDO3	in/out	P7DIR3	P7PLUD3	A11 : Address output (bp11) SEG14 : LCD segment output 14 SDO3 : Synchronous output 3
P74	A12 SEG13 SDO4	in/out	P7DIR4	P7PLUD4	A12 : Address output (bp12) SEG13 : LCD segment output 13 SDO4 : Synchronous output 4
P75	A13 SEG12 SDO5	in/out	P7DIR5	P7PLUD5	A13 : Address output (bp13) SEG12 : LCD segment output 12 SDO5 : Synchronous output 5
P76	A14 SEG11 SDO6	in/out	P7DIR6	P7PLUD6	A14 : Address output (bp14) SEG11 : LCD segment output 11 SDO6 : Synchronous output 6
P77	A15 SEG10 SDO7	in/out	P7DIR7	P7PLUD7	A15 : Address output (bp15) SEG10 : LCD segment output 10 SDO7 : Synchronous output 7
P80	D0 SEG2	in/out	P8DIR0	P8PLU0	D0 : Data I/O (bp0) SEG2 : LCD segment output 2
P81	D1 SEG3	in/out	P8DIR1	P8PLU1	D1 : Data I/O (bp1) SEG3 : LCD segment output 3
P82	D2 SEG4	in/out	P8DIR2	P8PLU2	D2 : Data I/O (bp2) SEG4 : LCD segment output 4
P83	D3 SEG5	in/out	P8DIR3	P8PLU3	D3 : Data I/O (bp3) SEG5 : LCD segment output 5
P84	D4 SEG6	in/out	P8DIR4	P8PLU4	D4 : Data I/O (bp4) SEG6 : LCD segment output 6
P85	D5 SEG7	in/out	P8DIR5	P8PLU5	D5 : Data I/O (bp5) SEG7 : LCD segment output 7
P86	D6 SEG8	in/out	P8DIR6	P8PLU6	D6 : Data I/O (bp6) SEG8 : LCD segment output 8
P87	D7 SEG9	in/out	P8DIR7	P8PLU7	D7 : Data I/O (bp7) SEG9 : LCD segment output 9
PA0	AN0	in	-	PAPLUD0	AN0 : Analog 0 input
PA1	AN1	in	-	PAPLUD1	AN1 : Analog 1 input
PA2	AN2	in	-	PAPLUD2	AN2 : Analog 2 input
PA3	AN3	in	-	PAPLUD3	AN3 : Analog 3 input
PA4	AN4	in	-	PAPLUD4	AN4 : Analog 4 input
PA5	AN5	in	-	PAPLUD5	AN5 : Analog 5 input
PA6	AN6	in	-	PAPLUD6	AN6 : Analog 6 input
PA7	AN7	in	-	PAPLUD7	AN7 : Analog 7 input
SEG0	SEG0	out	-	-	SEG0 : LCD segment output 0
SEG1	SEG1	out	-	-	SEG1 : LCD segment output 1
COM0	COM0	out	-	-	COM0 : LCD common output 0
COM1	COM1	out	-	-	COM1 : LCD common output 1
COM2	COM2	out	-	-	COM2 : LCD common output 2
COM3	COM3	out	-	-	COM3 : LCD common output 3

# START-UP PROCEDURE -CHART

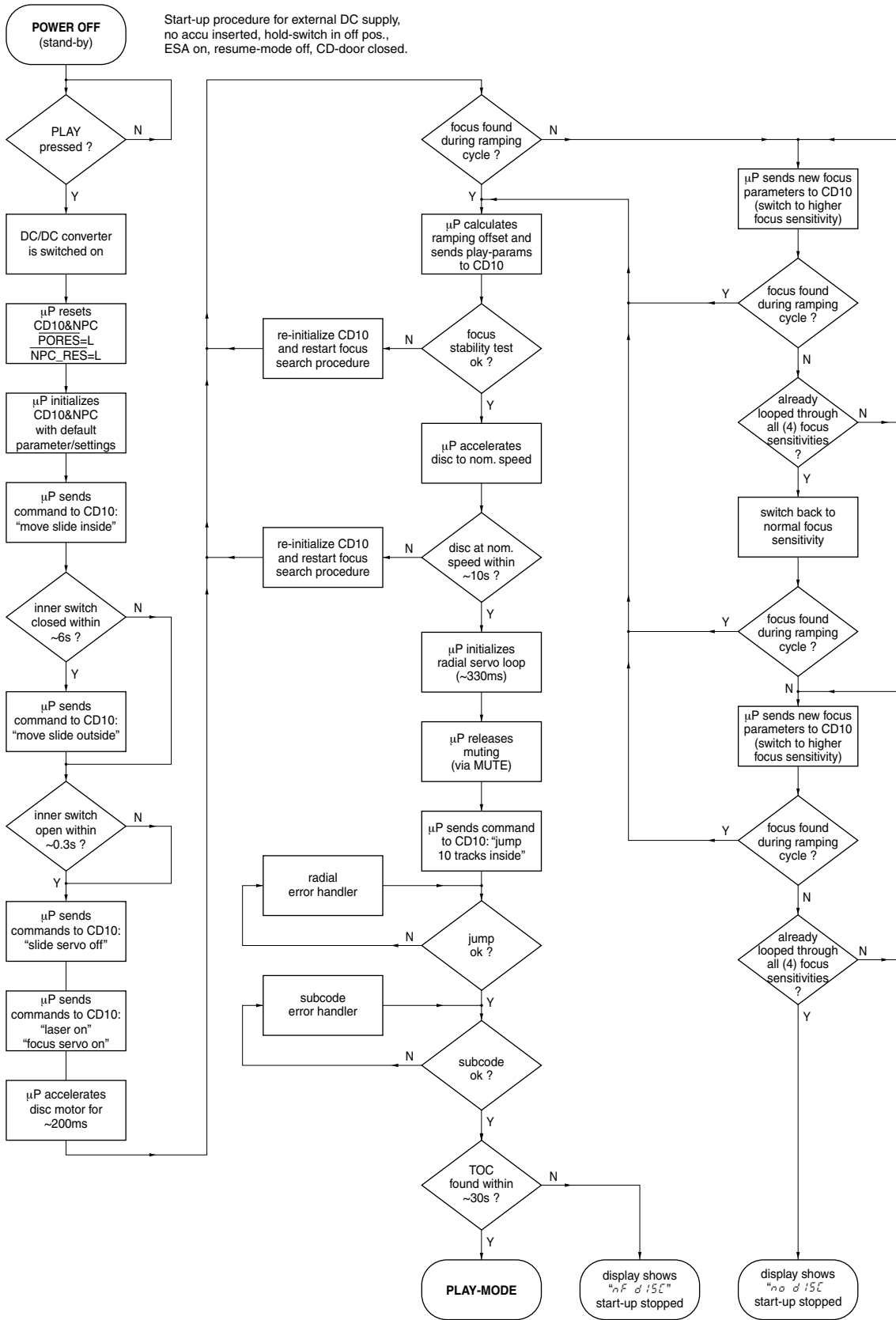

## SERVICE TEST PROGRAM

### 1. PRELIMINARY SETUP

- To enter the service test program disconnect the AC/DC adaptor and remove batteries, open the CD-door and hold the buttons "PLAY" & "PREV" depressed while turning power on (i.e. connecting the AC/DC adaptor).
- The display shows the software version of the built-in  $\mu\text{P}$  (i.e. "5-28"). Versions are counted from "00" onwards; that means the higher the number the newer the software.
- The program is now in the main menu – various tests can be entered by pressing the corresponding buttons (see flow chart on next page or detailed description of available tests below).
- To exit the service test program press the "STOP" button or disconnect the set from the power source.

### 2. DISPLAY TEST

Purpose: Check functionality of display and display driver.

- To enter the display test start the service test program and press the "NEXT" button.
- The display shows test pattern1. All segments are activated for finding open circuits (see flow chart on next page).
- To jump to the next pattern press the "NEXT" button.
- The display shows test pattern2. All alternate pins (2, 4, ...) are activated for finding short circuits (see flow chart on next page).
- To jump back to test pattern1 press the "NEXT" button, to exit the display test and return to the main menu press the "STOP" button.

### 3. KEY TEST

Purpose: Check operation of keys and cord remote control.

- To enter the key test start the service test program and press the "MODE" button.
- The display shows "--".
- Hold key depressed and check corresponding key code on the display. Key codes can be found in table1 (see flow chart on next page).
- To exit the key test and return to the main menu press the "STOP" button.

### 4. PLAYBACK TEST WITH ERROR ANALYSIS

Purpose: Analyze errors that occur during playback and search for intermittent failures.

- To enter the playback test start the service test program and press the "BASS" button.
- To start the error analysis press the "PLAY" button. Note that the playback test can only be entered if the CD-door is closed.
- The set will read the TOC and start playback.

As long as the playback is free of errors the display shows track and time information like in normal play-mode. In case of errors corresponding error codes will be displayed. The meaning of these error codes can be found in table2 (see flow chart on next page).

**Note:** Errors can either be "fatal" or "non fatal". Fatal errors always stop the playback, non fatal errors only cause a short interruption of the music. Fatal errors are displayed as long as the set is connected to the power source, non fatal errors are displayed until a new error occurs or a button is pressed.

- To stop the playback test disconnect the set from the power source.

### 5. SERVO TEST

Purpose: Check door switch, inner switch of CD-drive, movement of slide and acceleration of discmotor.

- To enter the servo test start the service test program and press the "PLAY" button.
- The display shows " $\overline{c} \overline{d} xy$ ".  
"x" indicates state of door switch;  
"y" indicates state of inner switch.  
 $x, y = "0"$  means switch is closed; " $1$ " means switch is open.
- To move slide outside hold the "NEXT" button depressed.
- To move slide inside hold the "PREV" button depressed.
- To accelerate the discmotor clockwise hold the "MODE" button depressed.
- To accelerate the discmotor counter-clockwise hold the "PROG" button depressed.
- To enter the focus test press the "PLAY" button, to exit the servo test and return to the main menu press the "STOP" button.

### 6. FOCUS TEST

Purpose: Check movement of lens and operation of focus servo for CDDA and CDRW discs.

Since the CDRW reflects much less light than an ordinary CDDA, the gain of the HF-amplifier stage and the sensitivity of the ADC inside the Decoder&Digital Servo IC "CD10" must be adapted accordingly. The gain is switched via the CDRW input of the HF-preamplifier. The ADC-sensitivity is set via software parameters (sent from  $\mu\text{P}$  to "CD10"). In total, there are 4 sensitivity modes available: 1 for CDDA and 3 for CDRW. The modes are listed in table3 (see next page). In normal play-mode, the correct focus sensitivity is chosen automatically during start-up (see "Start-up procedure" on previous page). In the service test program, the sensitivity can be chosen manually in order to allow individual measurements in several modes.

- The focus servo loop is switched on and the set starts searching the focus ("focus ramping"). As soon as the focus has been found the focus servo loop is closed and the state of the focus is monitored continuously.
- If the focus is OK the display shows " $F x$ ", else " $-F x$ ".  
"x" indicates the sensitivity mode. Details can be found in table3 (see flow chart on next page).
- To toggle between sensitivity modes press the "BASS" button.
- To move slide outside hold the "NEXT" button depressed.
- To move slide inside hold the "PREV" button depressed.
- To accelerate the discmotor clockwise hold the "MODE" button depressed.
- To accelerate the discmotor counter-clockwise hold the "PROG" button depressed.
- In case the focus is OK the discmotor test can be entered by pressing the "PLAY" button, to exit the focus test and return to the main menu press the "STOP" button.

### 7. DISCMOTOR TEST

Purpose: Check speed regulation of discmotor.

- The speed regulation is switched on and the discmotor starts rotating. If the speed reaches 75% of the nom. speed the display shows " $d$ ", else " $-d$ ".
- In parallel also the state of the focus is monitored continuously (display " $F x$ " or " $-F x$ ").
- In case the disc speed is OK and the focus is OK the radial test can be entered by pressing the "PLAY" button, to exit the discmotor test and return to the main menu press the "STOP" button.

### 8. RADIAL TEST

Purpose: Check if radial loop locks and an audio signal is audible at the headphone output.

- The radial servo loop is switched on, mute is released and the audio signal is audible. If the system is on track the display shows " $r$ ", else " $-r$ ".
- In parallel also the disc speed (display " $d$ " or " $-d$ ") and the state of the focus (display " $F x$ " or " $-F x$ ") are monitored continuously. Note: In case of radial errors the audio output is muted and muting is not released automatically when the systems recovers from the error. " $-r$ " remains on the display.  
To open mute again press the "NEXT" or "PREV" button.
- To jump 16 tracks outside press the "NEXT" button.
- To jump 16 tracks inside press the "PREV" button.
- To exit the radial test and return to the main menu press the "STOP" button, to exit the service test program disconnect the set from the power source.

#### Important remark:

In radial test mode data to the DRAM is written at 1.2 times the nominal speed, and read from the DRAM at nominal speed. Because writing is done faster than reading the DRAM gets full after a certain time.

In normal play mode the system would now wait until the DRAM is partly emptied again, jump backwards and resume filling at the last written position. However, in radial test mode the jumps would disturb measurements on the radial servo loop. Therefore this function has been disabled and filling restarts immediately from the current position of the pick-up unit. As a result "jumps" are audible during playback.

# SERVICE TEST PROGRAM - FLOW CHART

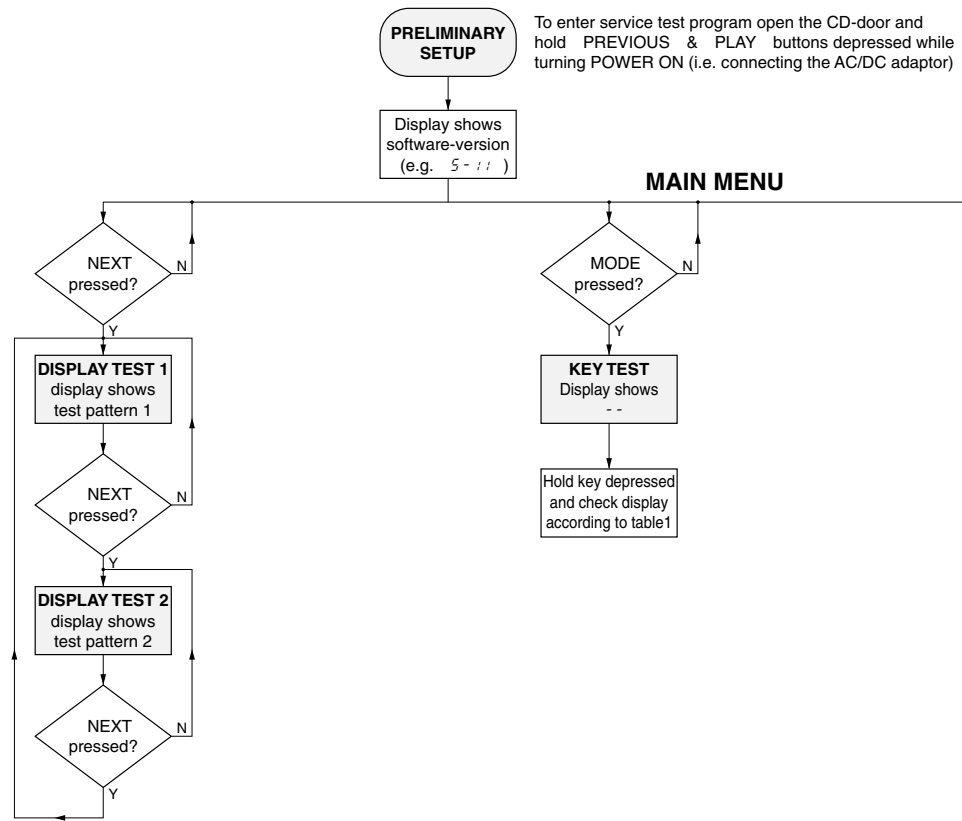

test pattern 1 (all segments activated)



test pattern 2 (alternate segments activated)

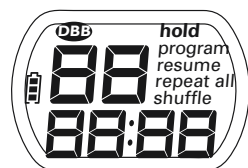

table1 — key test

KEY	DISPLAY
DBB	1
PROGRAM	2
MODE	3
PLAY	5
NEXT	6
PREVIOUS	7
ESP	8

Press "STOP" on the CD-player to exit the key test.

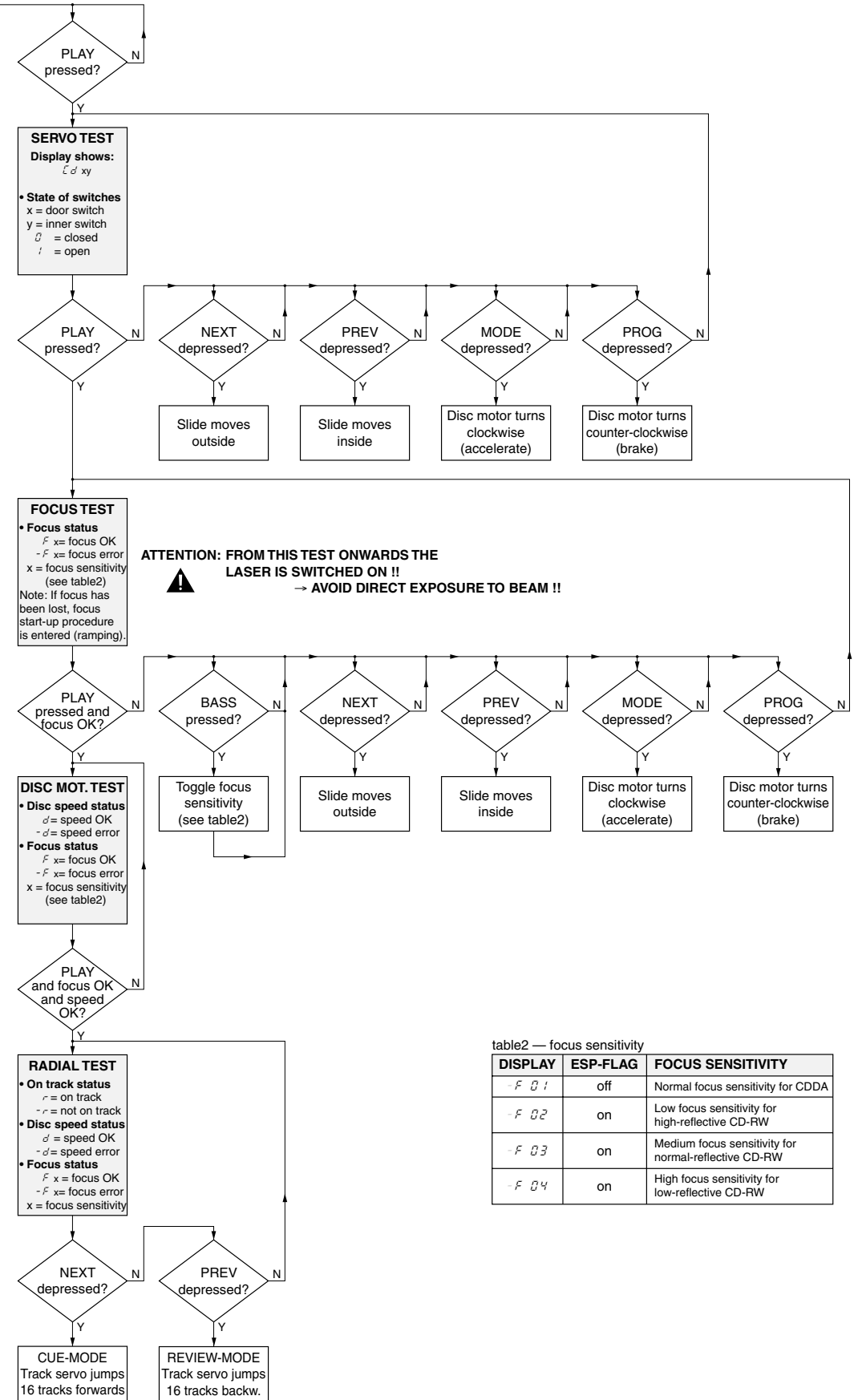
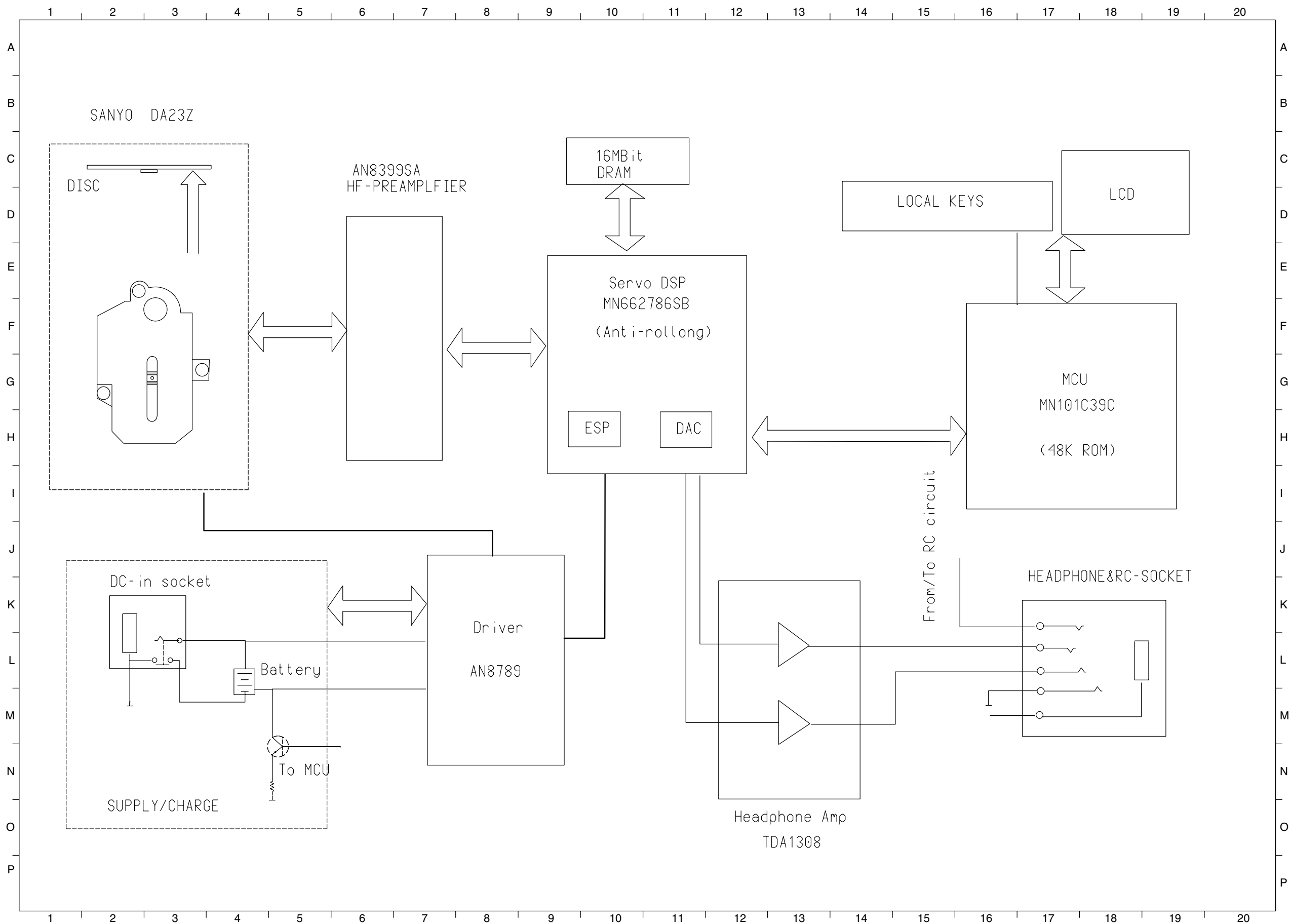

table2 — focus sensitivity

DISPLAY	ESP-FLAG	FOCUS SENSITIVITY
-F 01	off	Normal focus sensitivity for CDDA
-F 02	on	Low focus sensitivity for high-reflective CD-RW
-F 03	on	Medium focus sensitivity for normal-reflective CD-RW
-F 04	on	High focus sensitivity for low-reflective CD-RW

BLOCKDIAGRAM



# COMBI BOARD - CIRCUIT DIAGRAM

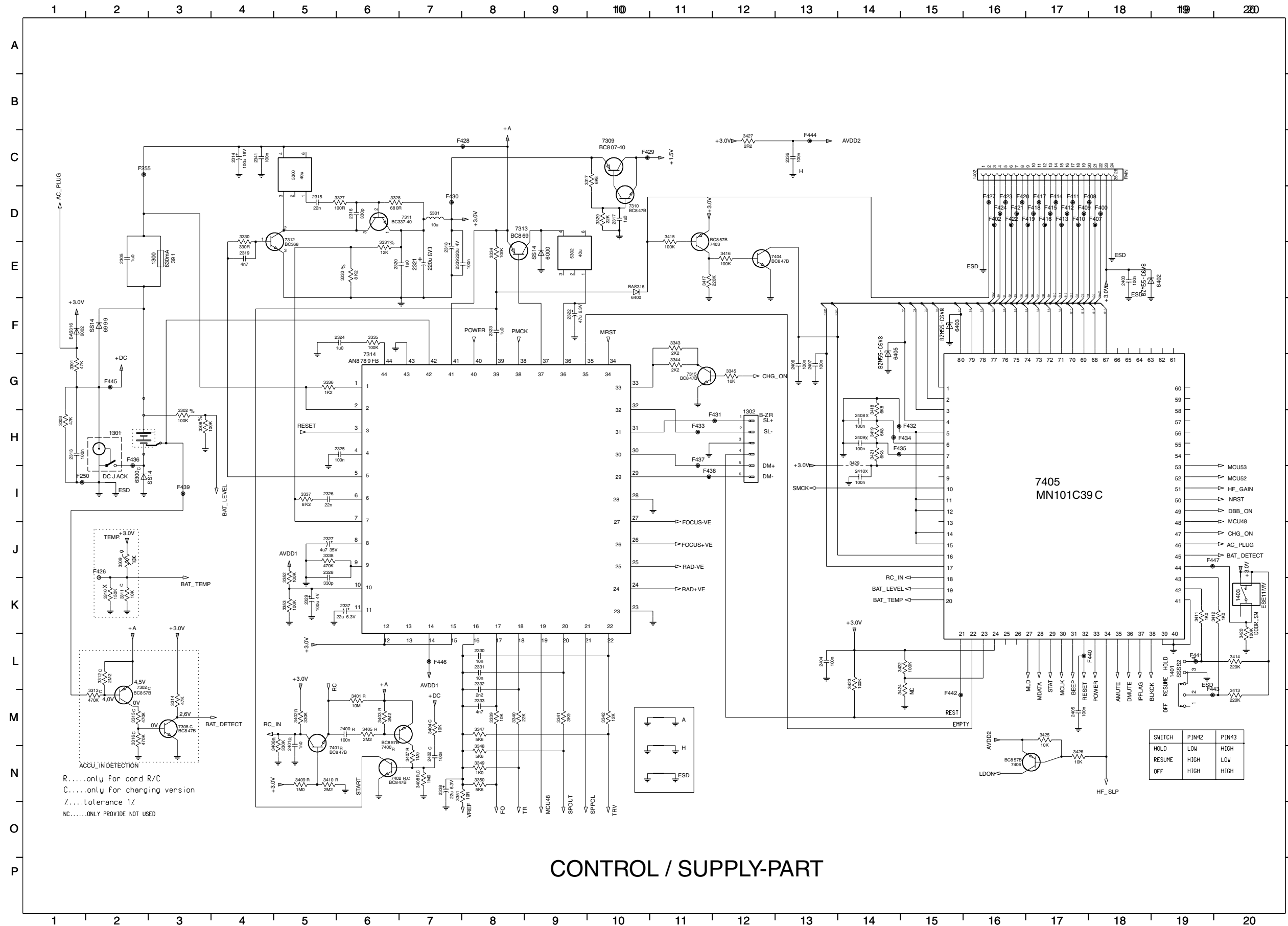

## CONTROL / SUPPLY-PART

R.....only for cord R/C  
 C.....only for charging version  
 Z.....tolerance 1/  
 NC.....ONLY PROVIDE NOT USED

SWITCH	PIN42	PIN43
HOLD	LOW	HIGH
RESUME	HIGH	LOW
OFF	HIGH	HIGH

- 1300 D3
- 1301 F2
- 1302 F10
- 1401 H16
- 1402 C13
- 1403 H17
- 2305 K3
- 2313 F2
- 2314 C4
- 2315 C5
- 2316 C5
- 2317 C9
- 2318 D7
- 2319 D4
- 2320 D6
- 2321 D6
- 2322 E8
- 2323 E7
- 2324 E5
- 2325 F5
- 2326 G5
- 2327 G5
- 2328 H5
- 2329 H5
- 2330 I7
- 2331 I7
- 2332 I7
- 2333 J7
- 2336 C11
- 2337 H5
- 2338 K6
- 2339 D7
- 2341 C4
- 2400 J5
- 2401 J5
- 2402 J6
- 2403 D15
- 2404 H11
- 2405 J15
- 2406 E11
- 2407 E11
- 2408 F12
- 2409 F12
- 2410 G12
- 3301 E2
- 3302 F3
- 3303 F2
- 3308 F3
- 3309 H2
- 3310 H2
- 3311 H2
- 3312 I2
- 3313 I2
- 3314 I3
- 3315 J3
- 3316 J3
- 3317 C8
- 3327 C5
- 3328 C6
- 3329 C8
- 3330 D4
- 3331 D6
- 3333 D5
- 3334 D7
- 3335 E6
- 3336 E5
- 3337 G5
- 3338 H5
- 3339 J7
- 3340 J7
- 3341 J8
- 3342 J9
- 3343 E9
- 3344 E9
- 3345 E10
- 3347 J7
- 3348 J7
- 3349 J7
- 3350 K7
- 3351 K7
- 3352 H4
- 3353 H4
- 3401 I5
- 3402 I5
- 3403 J6
- 3404 J6
- 3405 J5
- 3406 J4
- 3407 I6
- 3408 K6
- 3409 K5
- 3410 K5
- 3411 H16
- 3412 H16
- 3413 H7
- 3414 H7
- 3415 D10
- 3417 D10
- 3419 F12
- 3420 H7
- 3421 F12
- 3422 H12
- 3423 H12
- 3424 H12
- 3425 J14
- 3426 J15
- 3427 B10
- 3429 F12
- 5300 C5
- 5301 C6
- 5302 D8
- 6000 D8
- 6002 E2
- 6003 D9
- 6402 D16
- 6403 E12
- 6405 E12
- 6999 E2
- 7302 I3
- 7308 J3
- 7309 B9
- 7310 C9
- 7311 C6
- 7312 D4
- 7313 D8
- 7314 E6
- 7315 E10
- 7400 J6
- 7401 I5
- 7402 K6
- 7403 D10
- 7404 D11
- 7405 G14
- 7406 J14
- F250 G2
- F255 C3
- F400 C15
- F402 C15
- F407 C15
- F408 C15
- F409 C15
- F410 C15
- F411 C14
- F412 C14
- F413 C14
- F414 C14
- F415 C14
- F416 C14
- F417 C14
- F418 C14
- F419 C14
- F420 C14
- F421 C14
- F422 C14
- F423 C14
- F424 C14
- F425 C14
- F426 H2
- F427 C13
- F428 B7
- F429 C9
- F430 C7
- F431 F10
- F432 F12
- F433 F10
- F434 F12
- F435 F12
- F436 F2
- F437 F10
- F438 G10
- F439 G3
- F440 H3
- F441 H6
- F442 H6
- F443 H6
- F444 B11
- F445 E2
- F446 I6
- F447 H16



COMBI BOARD - CIRCUIT DIAGRAM

1500 C10	2511 B2	2523 B4	2528 C1	2533 D5	2538 A7	3504 A9	3510 B1	3517 B8	3522 B3	3533 B2	3543 C1	3548 C5	3553 D8	3558 B5	7500-A C7	7508 B4	7515 D6	F105 B2	F110 B7
2500 A6	2515 B1	2524 B9	2529 C1	2534 D7	3500 A5	3505 A4	3511 B1	3518 C3	3524 B7	3534 C3	3544 C1	3549 C8	3554 D7	6500 B8	7500-B A7	7510 B7	F101 A6	F106 C2	F111 C8
2501 A8	2516 B1	2525 C3	2530 C10	2535 E7	3501 A4	3506 A6	3513 B3	3519 B6	3525 B4	3535 C6	3545 C9	3550 C9	3555 D7	6501 B8	7501 B9	7511 B6	F102 B9	F107 C9	F112 E7
2502 A6	2520 B4	2526 C8	2531 C6	2536 B5	3502 A5	3507 A8	3514 B4	3520 B10	3526 B6	3539 C4	3546 C4	3551 D4	3556 D7	6502 C9	7503 B3	7512 C4	F103 B3	F108 D5	
2503 B7	2522 B9	2527 C2	2532 C8	2537 C6	3503 A8	3508 B7	3515 B7	3521 B4	3530 B8	3542 C7	3547 C5	3552 D6	3557 B5	6503 D5	7506 B6	7513 C9	F104 B9	F109 B5	

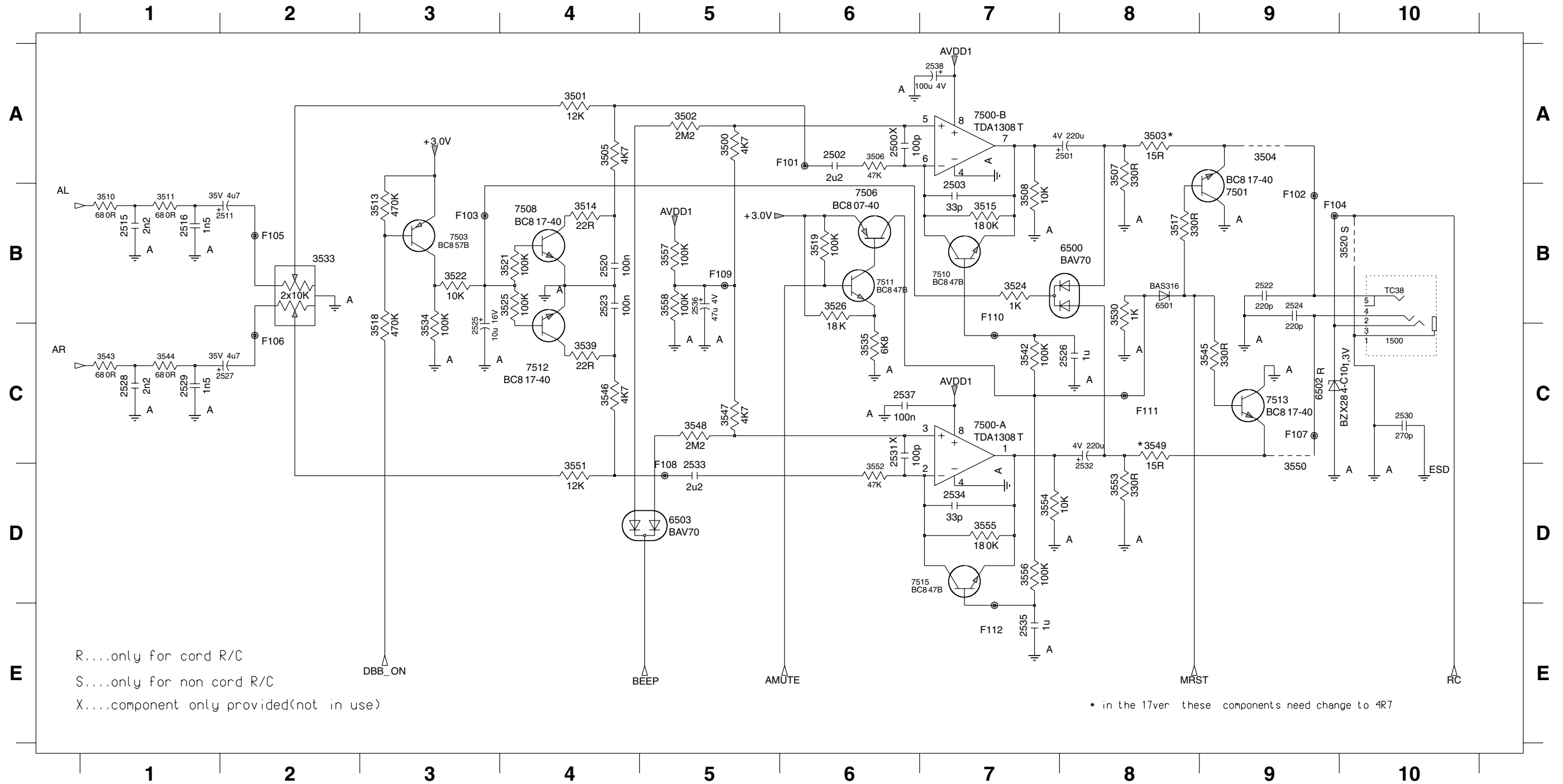

AUDIO-PART

# COMBI BAORD - CIRCUIT DIAGRAM

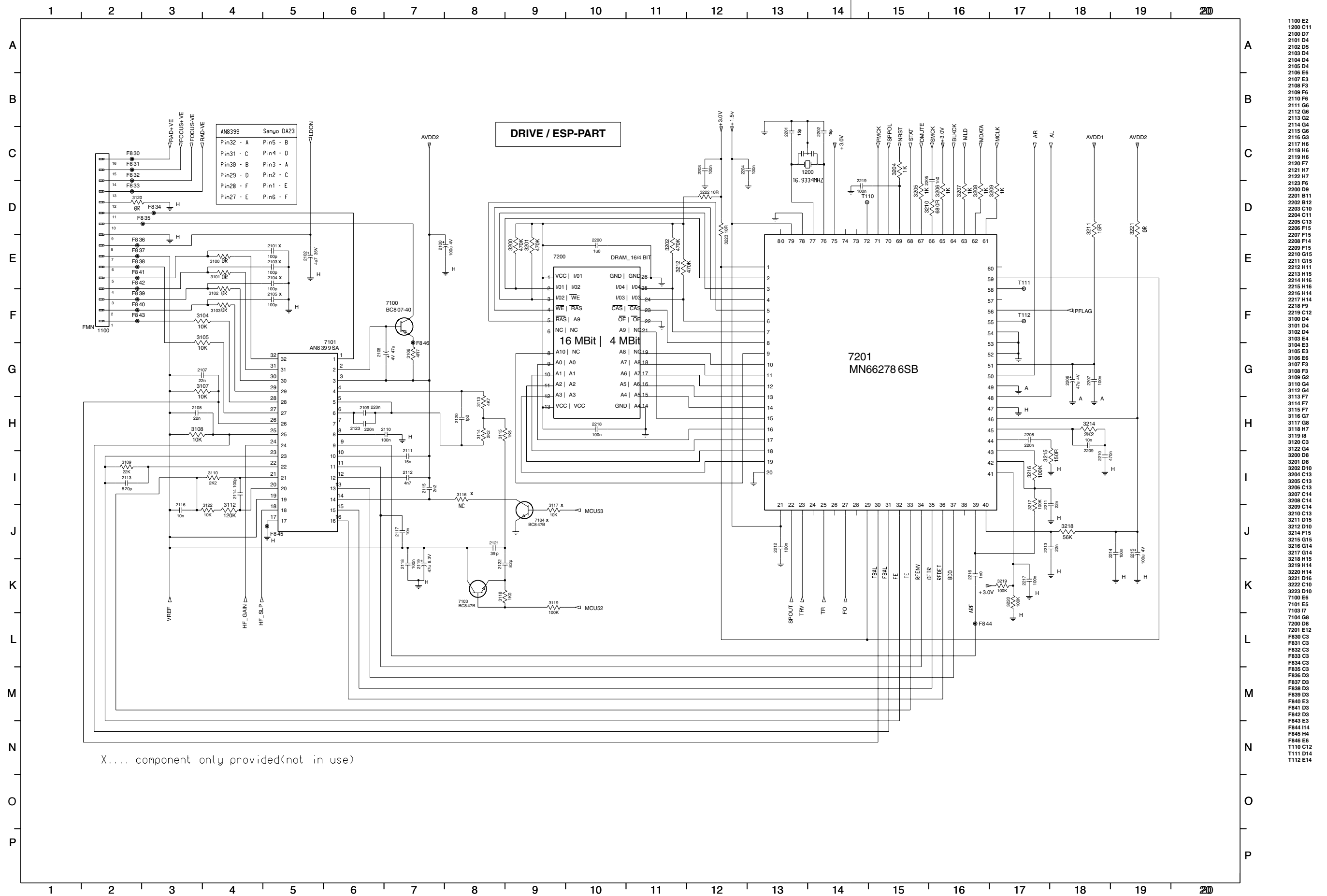

X... component only provided(not in use)

1100 E2  
1200 C11  
2100 D7  
2101 D4  
2102 D5  
2103 D4  
2104 D4  
2105 D4  
2106 E6  
2107 E3  
2108 F3  
2109 F6  
2110 F6  
2111 G6  
2112 G6  
2113 G2  
2114 G4  
2115 G6  
2116 G3  
2117 H6  
2118 H6  
2119 H6  
2120 F7  
2121 H7  
2122 H7  
2123 F6  
2200 D9  
2201 B11  
2202 B12  
2203 C10  
2204 C11  
2205 C13  
2206 F15  
2207 F15  
2208 F14  
2209 F15  
2210 G15  
2211 G15  
2212 H11  
2213 H15  
2214 H16  
2215 H16  
2216 H14  
2217 H14  
2218 F9  
2219 C12  
3100 D4  
3101 D4  
3102 D4  
3103 E4  
3104 E3  
3105 E3  
3106 E6  
3107 F3  
3108 F3  
3109 G2  
3110 G4  
3112 G4  
3113 F7  
3114 F7  
3115 F7  
3116 G7  
3117 G8  
3118 H7  
3119 I8  
3120 C3  
3122 G4  
3200 D8  
3201 D8  
3202 D10  
3204 C13  
3205 C13  
3206 C13  
3207 C14  
3208 C14  
3209 C14  
3210 C13  
3211 D15  
3212 D10  
3214 F15  
3215 G15  
3216 G14  
3217 G14  
3218 H15  
3219 H14  
3220 H14  
3221 D16  
3222 C10  
3223 D10  
7100 E6  
7101 E5  
7103 I7  
7104 G8  
7200 D8  
7201 E12  
F830 C3  
F831 C3  
F832 C3  
F833 C3  
F834 C3  
F835 C3  
F836 D3  
F837 D3  
F838 D3  
F839 D3  
F840 E3  
F841 D3  
F842 D3  
F843 E3  
F844 I14  
F845 H4  
F846 E6  
T110 C12  
T111 D14  
T112 E14





EXPLODED VIEW DIAGRAM - CABINET

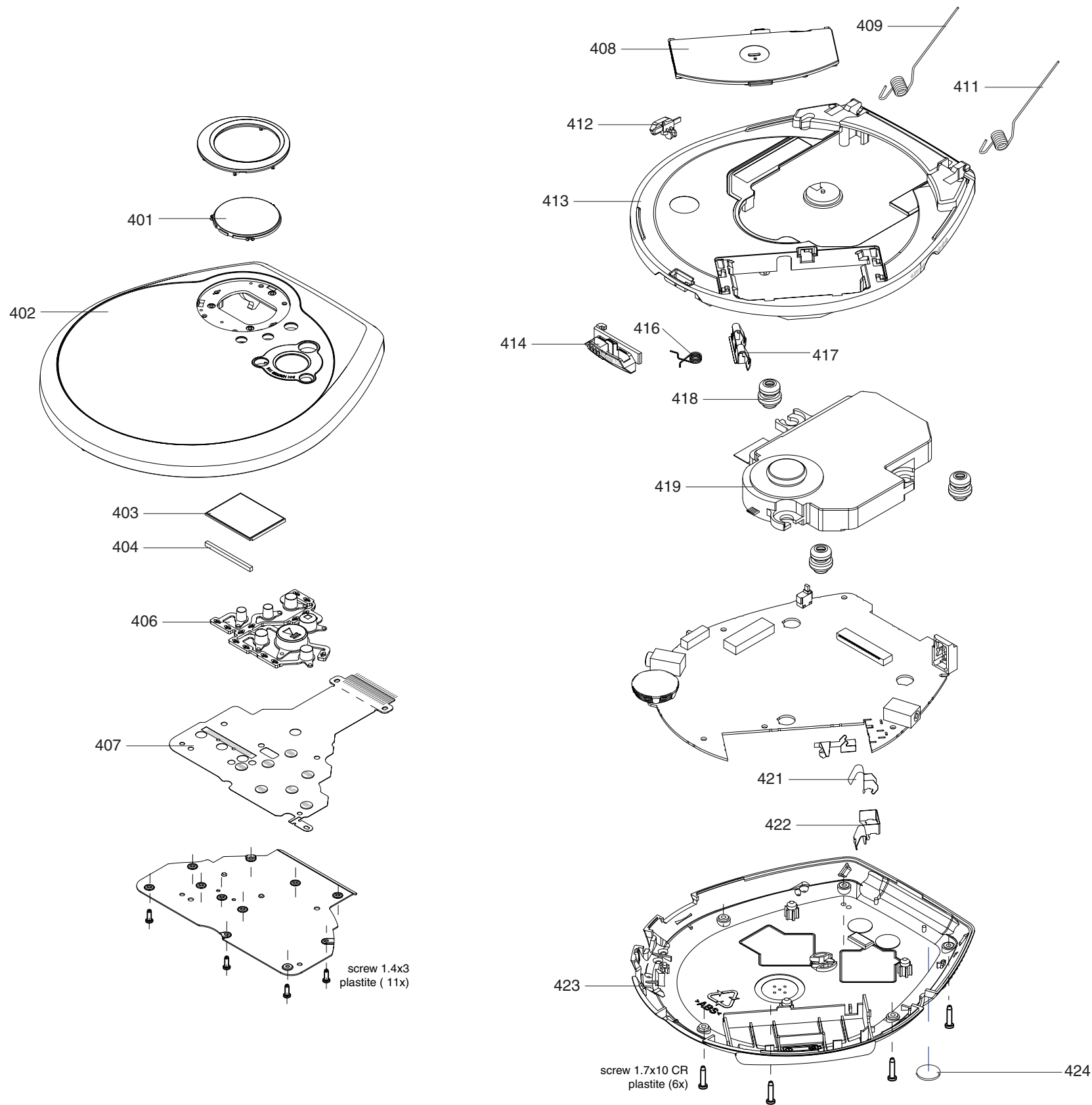

MECHANICAL PARTSLIST - CABINET

401	3140 117 66771	LCD LENS-PRT
402	3140 117 639 8 1	CD-DOOR ASSY-1
403	3140 110 5168 0	LCD PANEL
404	3140 114 468 31	ZEBRASTRIP
406	3140 117 6678 1	KNOBSET-PNT
407	3140 113 33020	KEY BOARD ASSY
408	3103 30799670	DOOR-BATTERY-LAC
409	3140 111 01371	CD-DOOR-SPRING-LEFT
411	3140 111 0138 1	CD-DOOR-SPRING-RIGHT
412	3103 304 69 570	SLIDER-RESUME
413	3103 304 69 540	COVER-BOTTOM
414	3103 304 69 58 0	SLIDER-OPEN
416	3103 301 06500	SPRING-SLIDER-OPEN-2
417	3103 301 4518 0	SPRING-BATTERY-SHORT-2
418	3103 3046959 0	SUSPENSION
419	3103 3090548 0	CDDA23ZPH
421	3103 301 45410	SPRING-BATTERY-MINUS
422	3103 301 45420	SPRING-BATTERY-PLUS
423	3103 307 9 9 620	BOTTOM-ASSY-1
424	48 22 462 418 19	RUBBER FOOT
	9 08 2 100 00615	HEADPHONE HE205/77
	3103 304 70250	BELT CLIP

**Note:** Only these parts mentioned in the list are normal service parts.



**ELECTRICAL PARTSLIST - COMBI BOARD****- MISCELLANEOUS -**

1100	4822 267 11027	CONNECTOR 16P
1300	△ 2422 086 10946	FUSE 630mA 65V
1301	2422 026 05086	CONNECTOR
1302	2422 025 12272	CONNECTOR 6P
1401	4822 277 21705	SWITCH
1402	4822 265 11248	CONNECTOR 24P
1403	2422 129 16818	PUSH SWITCH
1500	2422 026 05204	SOCKET PHONE H 1P

**- CAPACITORS -**

2100	4822 124 12108	100µF 20% 4V
2102	3198 030 74780	4,7µF 20% 35V
2106	4822 124 81058	47µF 20% 4V
2107	4822 126 14494	22nF 10% X7R 25V
2108	4822 126 14494	22nF 10% X7R 25V
2109	4822 126 13879	220nF +80-20% 16V
2110	2238 586 59812	100nF +80-20% Y5V 50V
2111	3198 017 31530	15nF X7R 50V
2112	4822 126 13193	4,7nF 10% X7R 63V
2113	3198 016 38210	820pF NP0 25V
2114	2020 552 94427	100pF 5% NP0 50V
2115	4822 126 14238	2,2nF X7R 50V
2116	5322 126 11583	10nF 10% X7R 50V
2117	5322 126 11583	10nF 10% X7R 50V
2118	2238 586 59812	100nF +80-20% Y5V 50V
2119	4822 124 80349	47µF 20% 6,3V
2121	2020 552 93645	39pF 5% NP0 50V
2122	4822 126 14226	82pF 5% NP0 50V
2200	3198 017 41050	1µF Y5V 10V
2201	4822 122 33752	15pF 5% NP0 50V
2202	4822 122 33752	15pF 5% NP0 50V
2203	2238 586 59812	100nF +80-20% Y5V 50V
2204	2238 586 59812	100nF +80-20% Y5V 50V
2205	5322 126 11578	1nF 10% X7R 50V
2206	4822 124 81058	47µF 20% 4V
2207	2238 586 59812	100nF +80-20% Y5V 50V
2208	4822 126 13879	220nF +80-20% 16V
2209	5322 126 11583	10nF 10% X7R 50V
2210	3198 017 44740	470nF Y5V 10V
2211	4822 126 14494	22nF 10% X7R 25V
2212	2238 586 59812	100nF +80-20% Y5V 50V
2213	4822 126 14494	22nF 10% X7R 25V
2214	2238 586 59812	100nF +80-20% Y5V 50V
2215	4822 124 12108	100µF 20% 4V
2216	3198 016 31020	1nF NP0 25V
2217	2238 586 59812	100nF +80-20% Y5V 50V
2218	2238 586 59812	100nF +80-20% Y5V 50V
2219	2238 586 59812	100nF +80-20% Y5V 50V
2305	3198 017 41050	1µF Y5V 10V
2313	2238 586 59812	100nF +80-20% Y5V 50V

**- CAPACITORS -**

2314	4822 124 12095	100µF 20% 16V
2315	3198 017 42230	22nF Y5V 50V
2316	4822 126 14241	330pF NP0 50V
2317	3198 017 41050	1µF Y5V 10V
2318	4822 124 42383	220µF 20% 4V
2319	4822 126 13193	4,7nF 10% X7R 63V
2320	3198 017 41050	1µF Y5V 10V
2321	4822 124 12245	220µF 20% 10V PM20 A
2322	4822 124 80349	47µF 20% 6,3V
2323	3198 017 41050	1µF Y5V 10V
2324	3198 017 41050	1µF Y5V 10V
2325	2238 586 59812	100nF +80-20% Y5V 50V
2326	3198 017 42230	22nF Y5V 50V
2327	3198 030 74780	20% 35V 4,7µF
2328	4822 126 14241	330pF NP0 50V
2329	4822 124 12108	100µF 20% 4V
2330	5322 126 11583	10nF 10% X7R 50V
2331	5322 126 11583	10nF 10% X7R 50V
2332	4822 126 14238	2,2nF X7R 50V
2333	4822 126 13193	4,7nF 10% X7R 63V
2336	2238 586 59812	100nF +80-20% Y5V 50V
2337	4822 124 23237	22µF 6,3V
2338	4822 124 23237	22µF 6,3V
2339	2238 586 59812	100nF +80-20% Y5V 50V
2341	2238 586 59812	100nF +80-20% Y5V 50V
2403	2238 586 59812	100nF +80-20% Y5V 50V
2404	2238 586 59812	100nF +80-20% Y5V 50V
2405	2238 586 59812	100nF +80-20% Y5V 50V
2406	2238 586 59812	100nF +80-20% Y5V 50V
2407	2238 586 59812	100nF +80-20% Y5V 50V
2501	4822 124 42383	220µF 20% 4V
2502	4822 126 14491	2,2µF 10V
2503	2222 867 15339	33pF 5% NP0 50V
2511	3198 030 74780	4,7µF 20% 35V
2515	4822 126 14238	2,2nF X7R 50V
2516	4822 126 14247	1,5nF X7R 50V
2520	2238 586 59812	100nF +80-20% Y5V 50V
2522	4822 126 13883	220pF 5% 50V
2523	2238 586 59812	100nF +80-20% Y5V 50V
2524	4822 126 13883	220pF 5% 50V
2525	4822 124 23002	10µF 16V
2526	3198 017 41050	1µF Y5V 10V
2527	3198 030 74780	4,7µF 20% 35V
2528	4822 126 14238	2,2nF X7R 50V
2529	4822 126 14247	1,5nF X7R 50V
2530	4822 126 14506	270pF 5% 50V NP0
2532	4822 124 42383	220µF 20% 4V
2533	4822 126 14491	2,2µF 10V
2534	2222 867 15339	33pF 5% NP0 50V
2535	3198 017 41050	1µF Y5V 10V



**ELECTRICAL PARTSLIST - COMBI BOARD****- CAPACITORS -**

2536	4822 124 81058	47µF 20% 4V
2537	2238 586 59812	100nF +80-20% Y5V 50V
2538	4822 124 12108	100µF 20% 4V

**- RESISTORS -**

3100	4822 051 30008	OR JUMPER
3101	4822 051 30008	OR JUMPER
3102	4822 051 30008	OR JUMPER
3103	4822 051 30008	OR JUMPER
3104	4822 051 30103	10K 5% 0,062W
3105	4822 051 30103	10K 5% 0,062W
3106	4822 117 13608	4,7R 5% 0,0016W
3107	4822 051 30103	10K 5% 0,062W
3108	4822 051 30103	10K 5% 0,062W
3109	4822 051 30223	22K 5% 0,062W
3110	4822 051 30222	2,2K 5% 0,062W
3112	4822 051 30124	120K 5% 0,062W
3113	4822 051 30472	4,7K 5% 0,062W
3114	4822 051 30222	2,2K 5% 0,062W
3115	4822 051 30152	1,5K 5% 0,062W
3118	4822 051 30102	1K 5% 0,062W
3119	4822 117 13632	100K 1% 0,62W
3120	4822 051 30008	OR JUMPER
3122	4822 051 30103	10K 5% 0,062W
3200	4822 051 30474	470K 5% 0,062W
3201	4822 051 30474	470K 5% 0,062W
3202	4822 051 30474	470K 5% 0,062W
3204	4822 051 30102	1K 5% 0,062W
3205	4822 051 30102	1K 5% 0,062W
3206	4822 051 30102	1K 5% 0,062W
3207	4822 051 30102	1K 5% 0,062W
3208	4822 051 30102	1K 5% 0,062W
3209	4822 051 30102	1K 5% 0,062W
3210	4822 051 30681	680R 5% 0,062W
3211	4822 117 12971	15R 5% 0,62W
3212	4822 051 30474	470K 5% 0,062W
3214	4822 051 30222	2,2K 5% 0,062W
3215	4822 051 30151	150R 5% 0,062W
3216	4822 117 13632	100K 1% 0,62W
3217	4822 117 13632	100K 1% 0,62W
3218	4822 051 30563	56K 5% 0,062W
3219	4822 117 13632	100K 1% 0,62W
3220	4822 117 13632	100K 1% 0,62W
3221	4822 117 12971	15R 5% 0,62W
3222	4822 051 30109	10R 5% 0,062W
3223	4822 051 30109	10R 5% 0,062W
3301	4822 117 12925	47K 1% 0,063W
3302	4822 117 13632	100K 1% 0,62W
3303	4822 117 12925	47K 1% 0,063W
3308	4822 117 13632	100K 1% 0,62W

**- RESISTORS -**

3314	4822 117 12925	47K 1% 0,063W
3317	4822 051 30682	6,8K 5% 0,062W
3327	4822 051 30101	100R 5% 0,062W
3328	4822 051 30681	680R 5% 0,062W
3329	4822 051 30223	22K 5% 0,062W
3330	4822 051 30331	330R 5% 0,062W
3331	5322 117 13028	12K 1% 0,063W
3333	5322 117 13056	8,2K 1% 0,063W
3334	4822 117 13632	100K 1% 0,62W
3335	4822 117 13632	100K 1% 0,62W
3336	4822 117 11817	1,2K 1% 1/16W
3337	4822 117 12902	8,2K 1% 0,063W
3338	4822 051 30474	470K 5% 0,062W
3339	4822 051 30103	10K 5% 0,062W
3340	4822 051 30223	22K 5% 0,062W
3341	4822 051 30392	3,9K 5% 0,063W
3342	4822 051 30123	12K 5% 0,062W
3347	4822 051 30562	5,6K 5% 0,063W
3348	4822 051 30562	5,6K 5% 0,063W
3349	4822 051 30102	1K 5% 0,062W
3350	4822 051 30562	5K6 5% 0,063W
3351	4822 051 30109	10R 5% 0,062W
3352	4822 117 13632	100K 1% 0,62W
3353	4822 117 13632	100K 1% 0,62W
3402	4822 051 30008	OR JUMPER
3411	4822 051 30102	1K 5% 0,062W
3412	4822 051 30102	1K 5% 0,062W
3413	4822 117 12891	220K 1%
3414	4822 117 12891	220K 1%
3415	4822 117 13632	100K 1% 0,62W
3416	4822 117 13632	100K 1% 0,62W
3417	4822 117 12891	220K 1%
3418	4822 051 30682	6,8K 5% 0,062W
3419	4822 051 30682	6,8K 5% 0,062W
3420	4822 117 13632	100K 1% 0,62W
3421	4822 051 30682	6,8K 5% 0,062W
3423	4822 117 13632	100K 1% 0,62W
3424	4822 051 30008	OR JUMPER
3425	4822 051 30103	10K 5% 0,062W
3426	4822 051 30103	10K 5% 0,062W
3427	4822 051 20158	1,5R 5% 0,1W
3429	4822 051 30008	OR JUMPER
3500	4822 051 30472	4,7K 5% 0,062W
3501	4822 051 30123	12K 5% 0,062W
3502	3198 021 32250	2,2M 5%
3503	4822 117 12971	15R 5% 0,62W
3504	4822 051 30008	OR JUMPER
3505	4822 051 30472	4,7K 5% 0,062W
3506	4822 117 12925	47K 1% 0,063W
3507	4822 051 30331	330R 5% 0,062W

**ELECTRICAL PARTSLIST - COMBI BOARD****- RESISTORS -**

3508	4822 051 30103	10K 5% 0,062W
3510	4822 051 30681	680R 5% 0,062W
3511	4822 051 30681	680R 5% 0,062W
3513	4822 051 30474	470K 5% 0,062W
3514	4822 117 12139	22R 5% 0,062W
3515	2322 702 60184	180K 5%
3517	4822 051 30331	330R 5% 0,062W
3518	4822 051 30474	470K 5% 0,062W
3519	4822 117 13632	100K 1% 0,62W
3520	4822 051 30008	OR JUMPER
3521	4822 117 13632	100K 1% 0,62W
3522	4822 051 30103	10K 5% 0,062W
3524	4822 051 30102	1K 5% 0,062W
3525	4822 117 13632	100K 1% 0,62W
3526	4822 051 30183	18K 5% 0,062W
3530	4822 051 30102	1K 5% 0,062W
3533	2122 400 00001	10KX2 H F-1001G
3534	4822 117 13632	100K 1% 0,62W
3535	4822 051 30682	6,8K 5% 0,062W
3539	4822 117 12139	22R 5% 0,062W
3542	4822 117 13632	100K 1% 0,62W
3543	4822 051 30681	680R 5% 0,062W
3544	4822 051 30681	680R 5% 0,062W
3545	4822 051 30331	330R 5% 0,062W
3546	4822 051 30472	4,7K 5% 0,062W
3547	4822 051 30472	4,7K 5% 0,062W
3548	3198 021 32250	2,2M 5%
3549	4822 117 12971	15R 5% 0,62W
3550	4822 051 30008	OR JUMPER
3551	4822 051 30123	12K 5% 0,062W
3552	4822 117 12925	47K 1% 0,063W
3553	4822 051 30331	330R 5% 0,062W
3554	4822 051 30103	10K 5% 0,062W
3555	2322 702 60184	180K 5%
3556	4822 117 13632	100K 1% 0603 0,62W
3557	4822 117 13632	100K 1% 0603 0,62W
3558	4822 117 13632	100K 1% 0603 0,62W

**- COILS & FILTERS -**

1200	4822 242 81865	CST16,93MXW0C3-TF01
5300	2422 536 00346	IND VAR 5MM 5HP 40µH
5301	4822 157 51462	10µH 10% 4X9,8MM 100K
5302	2422 536 00346	IND VAR 5MM 5HP 40µH

**- DIODES -**

6000	9322 128 70685	SS14 (GI00)
6002	4822 130 11397	BAS316
6400	4822 130 11397	BAS316
6402	9322 129 38685	BZM55-C6V8
6403	9322 129 38685	BZM55-C6V8
6405	9322 129 38685	BZM55-C6V8
6500	5322 130 34331	BAV70
6501	4822 130 11397	BAS316
6503	5322 130 34331	BAV70
6999	9322 128 70685	SS14 (GI00)

**- IC & TRANSISTORS -**

7100	5322 130 60123	BC807-40
7101	9322 182 66671	AN8399SA
7103	5322 130 60159	BC846B
7200	9322 175 89668	MSM51V17405F-60SJ
7201	9322 182 62671	MN662786SB
7309	5322 130 60123	BC807-40
7310	5322 130 60159	BC846B
7311	4822 130 40855	BC337
7312	5322 130 44647	BC368
7313	4822 130 60142	BC869
7314	9322 186 71671	AN8789FB
7403	4822 130 60373	BC856B
7404	5322 130 60159	BC846B
7405	3140 110 51710	MN101C39C
7406	4822 130 60373	BC856B
7500	4822 209 33165	TDA1308T/N1
7501	4822 130 42615	BC817-40
7503	4822 130 60373	BC856B
7506	5322 130 60123	BC807-40
7508	4822 130 42615	BC817-40
7510	5322 130 60159	BC846B
7511	5322 130 60159	BC846B
7512	4822 130 42615	BC817-40
7513	4822 130 42615	BC817-40
7515	5322 130 60159	BC846B

**Note: Only these parts mentioned in the list are normal service parts.**